

Body Specifications / Wheel Alignment

Unit: mm (in.)

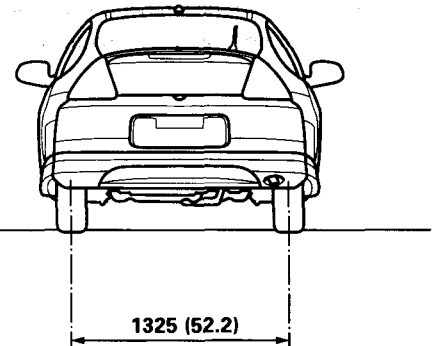
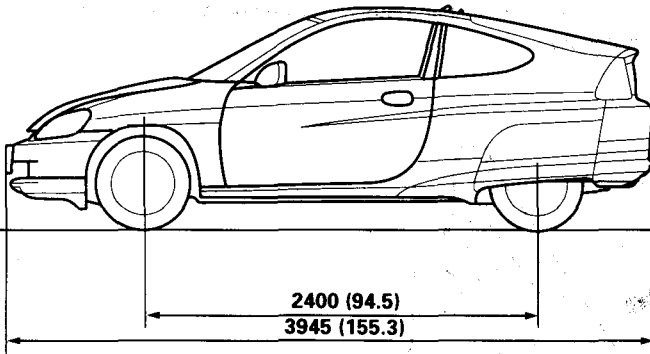
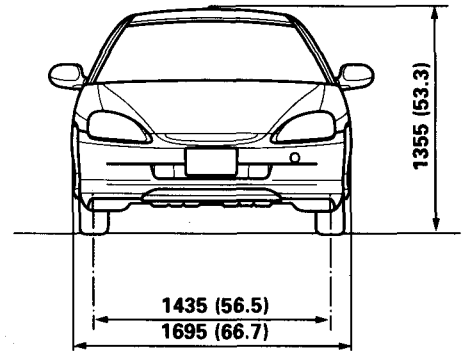
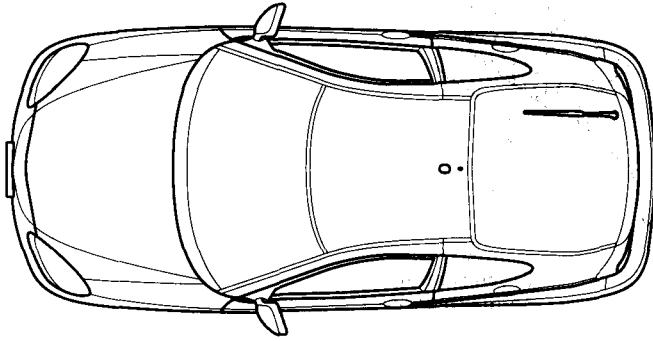

Front wheel alignment:

Camber	0°00'±1°	
Caster	2°00'±1°	
Total toe	0±2 (0±0.08)	
Wheel turning angle	in	40°00'±2°
	out	33°00' (Reference)

Rear wheel alignment:

Camber	-1°00'±1°
Total toe	IN 3±3 (0.12±0.12)