

# Advanced Diagnostics

## DTC P1646: MOTSTB Signal Malfunction

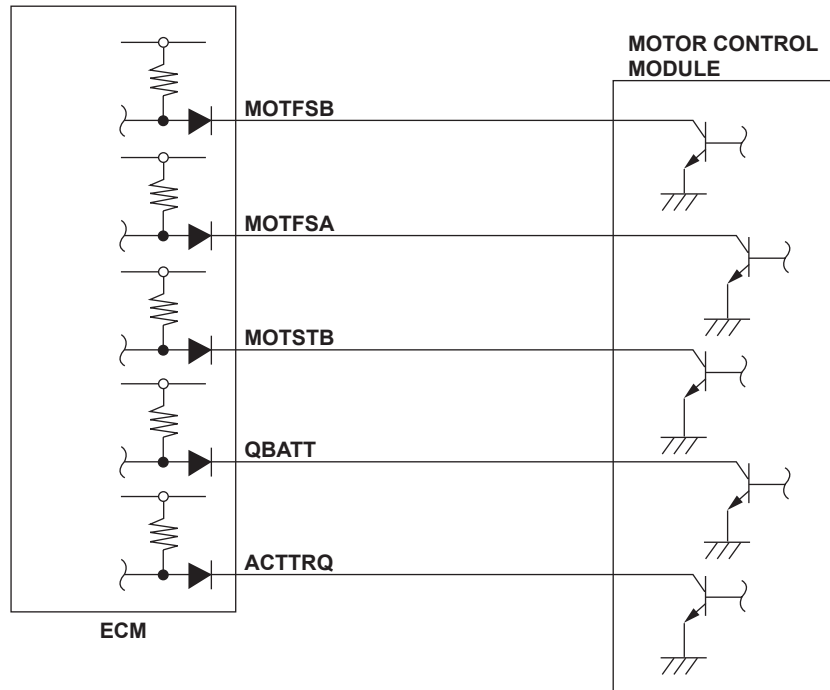

P1640-0001

### General Description

The motor control module (MCM) sends information about the motor to the engine control module (ECM) via the MOTSTB signal line. If no duty signals are input from the MCM for a set time, the ECM detects a malfunction and stores a DTC.

### Monitor Execution, Sequence, Duration, DTC Type

Execution	Continuous
Sequence	None
Duration	5 seconds or more
DTC Type	One drive cycle, MIL ON

### Enable Conditions

Condition	Minimum	Maximum
Battery voltage	10.05 V	—
Ignition switch	ON	
No active DTCs	IMA MOTSTB	

## **Malfunction Threshold**

No signals from the MCM are input for at least 5 seconds.

## **Diagnosis Details**

### **Conditions for illuminating the MIL**

When a malfunction is detected, the MIL comes on and the DTC and the freeze frame data are stored in the ECM memory.

### **Conditions for clearing the MIL**

The MIL will be cleared if the malfunction does not recur during three consecutive trips in which the diagnostic runs.

The MIL, the DTC, and the freeze frame data can be cleared by using the scan tool Clear command or by disconnecting the battery.