

Advanced Diagnostics

DTC P1642: QBATT Battery Signal Circuit Low Input

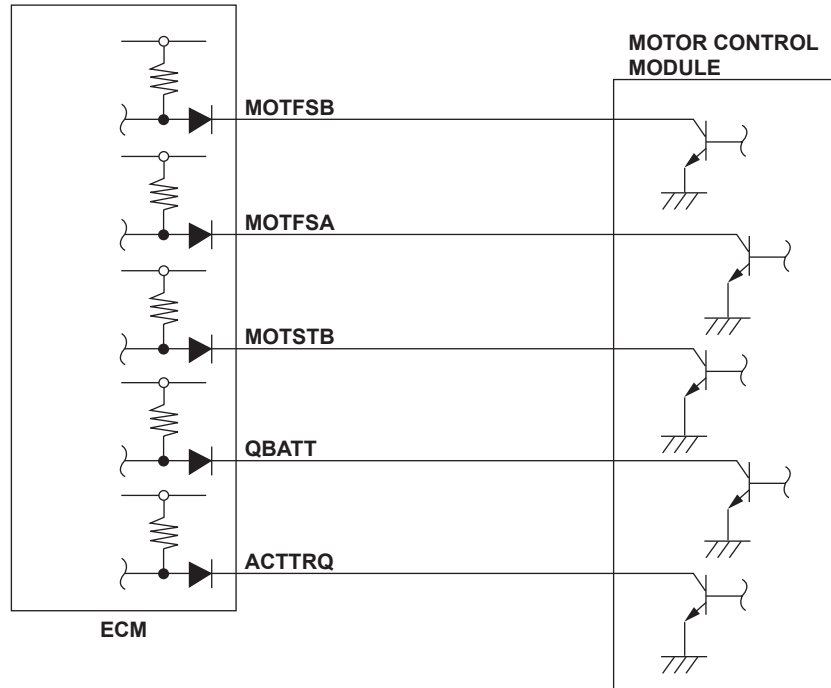

P1640-0001

General Description

The motor control module (MCM) signals the information about the battery's state of charge to the engine control module (ECM) via the QBATT signal line. If the QBATT battery signal voltage is a set value or less, a malfunction is detected and a DTC is stored.

Monitor Execution, Sequence, Duration, DTC Type

Execution	Continuous
Sequence	None
Duration	5 seconds or more
DTC Type	One drive cycle, MIL ON

Enable Conditions

Condition	Minimum	Maximum
Battery voltage	10.05 V	—
Ignition switch	ON	
No active DTCs	IMA QBATT signal	

Malfunction Threshold

The QBATT battery signal voltage is 0.27 V or less for at least 5 seconds.

Diagnosis Details

Conditions for illuminating the MIL

When a malfunction is detected, the MIL comes on and the DTC and the freeze frame data are stored in the ECM memory.

Conditions for clearing the MIL

The MIL will be cleared if the malfunction does not recur during three consecutive trips in which the diagnostic runs.

The MIL, the DTC, and the freeze frame data can be cleared by using the scan tool Clear command or by disconnecting the battery.