

Advanced Diagnostics

DTC P1582 (25): Motor Current U Phase Signal Circuit High Input

U Phase Motor Current Sensor Output Voltage

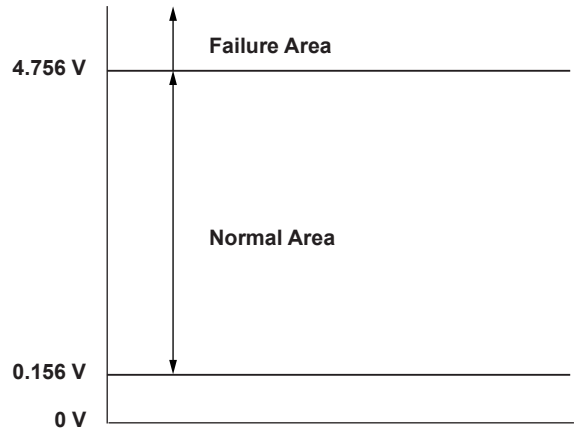
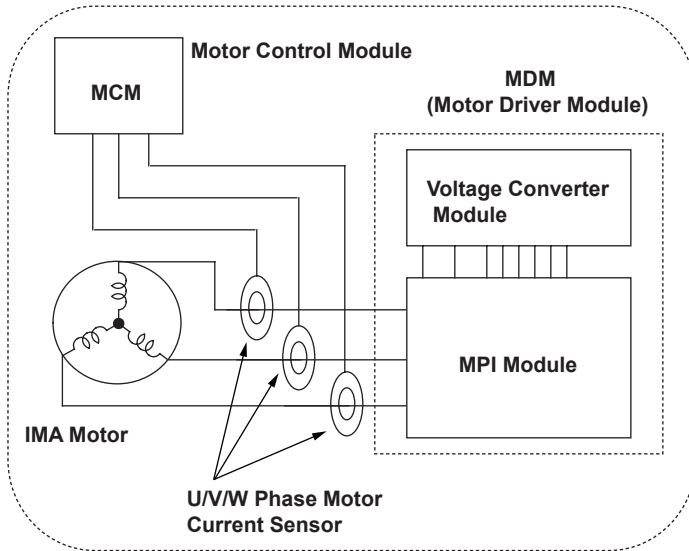

P1582-0072

General Description

If the input voltage to the MCM (motor control module) from the U phase motor current sensor is beyond the upper limit of a set value, a faulty sensor, an open in the sensor ground or the faulty MCM input circuit is detected and a DTC is stored.

Monitor Execution, Sequence, Duration, DTC Type

Execution	Continuous
Sequence	None
Duration	0.5 second or more
DTC Type	One drive cycle, MIL ON, IMA system indicator ON

Enable Conditions

Condition	Minimum	Maximum
MCM power-supply voltage	10.5 V	—
Ignition switch	ON	
No active DTCs	MCM	

Malfunction Threshold

The input voltage from the U phase motor current sensor is more than 4.756 V for at least 0.5 second.

Diagnosis Details

Conditions for illuminating the MIL

When a malfunction is detected, the MIL comes on and the DTC and the freeze frame data are stored in the ECM memory.

Conditions for clearing the MIL

The MIL will be cleared if the malfunction does not recur during three consecutive trips in which the diagnostic runs.

The MIL, the DTC, and the freeze frame data can be cleared by using the scan tool Clear command or by disconnecting the battery.