

Advanced Diagnostics

DTC P1440 (57): IMA System Problem

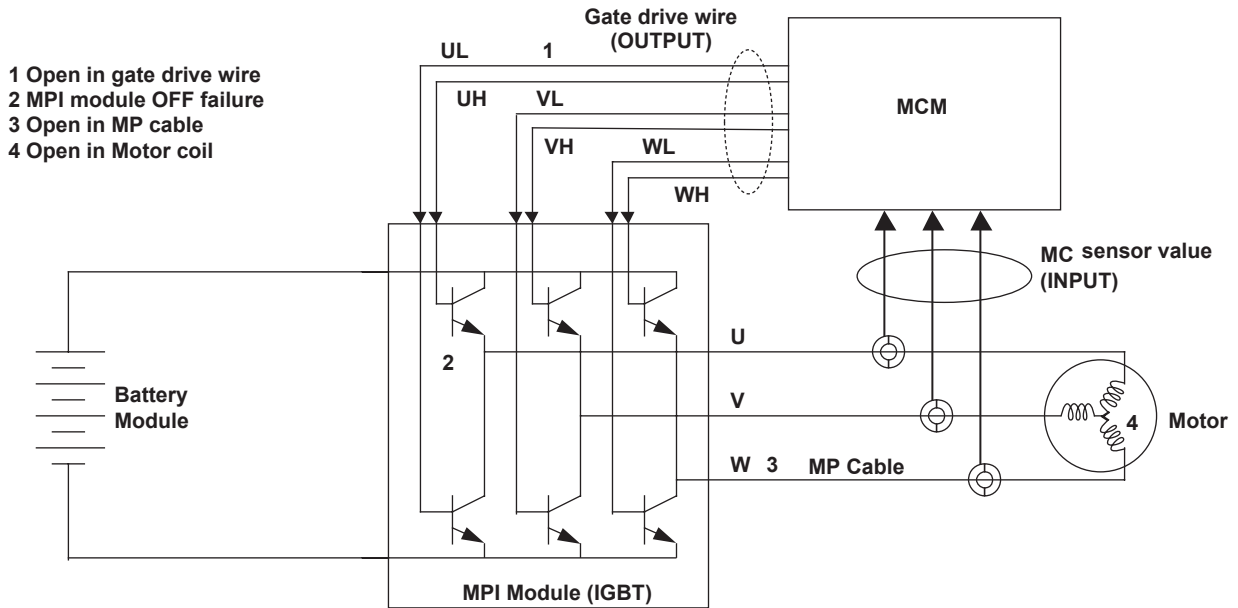

P1440-0071

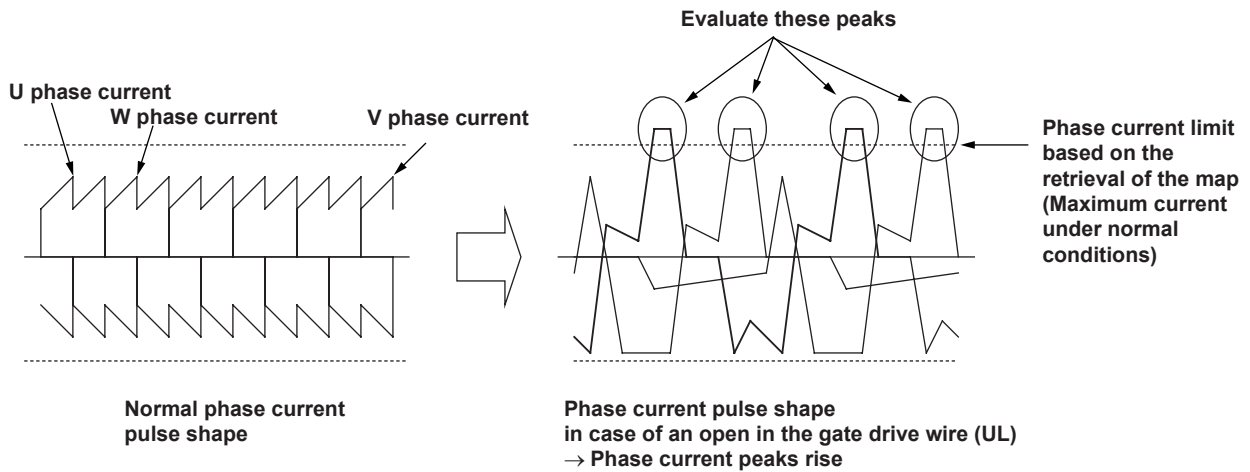

P1440-0072

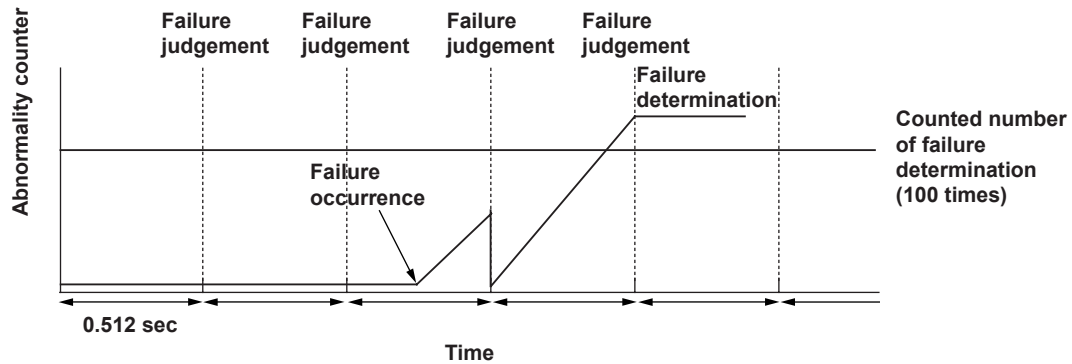

P1440-0073

General Description

An open in the gate drive wire, the insulated gate bipolar transistor (IGBT) OFF failure, and an open in the motor power cable or in the motor coil causes deviation from the target value of torque in the integrated motor assist (IMA) system. By monitoring changes in phase current when an abnormality occurs, the function monitor detects a malfunction in the IMA system. An open in the gate drive wire or in the MP cable causes an increase in two other normal phases' current to compensate for a decrease in the phase when the motor control range is not in the low speed range.

Monitor Execution, Sequence, Duration, DTC Type

Execution	Continuous
Sequence	None
Duration	0.512 second or more
DTC Type	One drive cycle, MIL ON, IMA system indicator ON

Enable Conditions

Condition	Minimum	Maximum
MCM power-supply voltage	10.5 V	—
Motor speed	2,000 rpm	—
Motor driving torque	10 N•m (1 kgf•m, 7.2 lbf•ft)	—
Battery module voltage	120 V	192 V
No active DTCs	MDM, MPI, U/V/W phase signal circuit, MCM, IMA system, BCM, BC	

Malfunction Threshold

The number of times that the three MC sensors output values exceed the value based on the retrieval of the map (current used for failure determination) depending on the demanded motor torque, battery module voltage, and speed while the cycle time is at least 0.512 second has been counted 100 times or more.

Driving Pattern

1. Start the engine.
2. Accelerate the vehicle to an engine speed of 2,000 rpm or more with wide open throttle while 10 segments or more on the IMA battery charge gauge are illuminated.

Diagnosis Details

Conditions for illuminating the MIL

When a malfunction is detected, the MIL comes on and the DTC and the freeze frame data are stored in the ECM memory.

Conditions for clearing the MIL

The MIL will be cleared if the malfunction does not recur during three consecutive trips in which the diagnostic runs.

The MIL, the DTC, and the freeze frame data can be cleared by using the scan tool Clear command or by disconnecting the battery.