

Accessory	Application	Publications No.
<b>SECURITY SYSTEM</b>	<b>2002 INSIGHT</b>	<b>All 23273</b>
		Issue Date <b>OCT 2001</b>

## PARTS LIST

**Security System:  
P/N 08E51-S84-100**

2 Remote controls

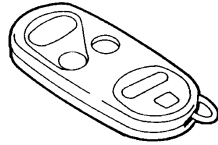

Control unit

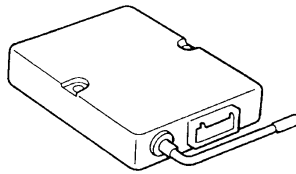

LED

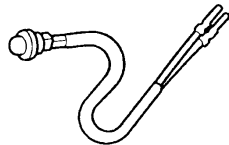

Push nut



2-Pin connector (for LED)

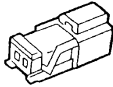

Disarm switch

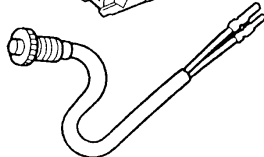

Window decal

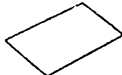

3-Pin connector  
(for disarm switch)

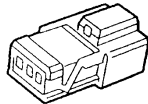

Nut, 12 mm



Washer



Owner's Manual

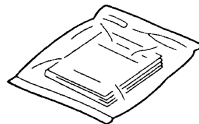

2 Washer-screws, 4 x 30 mm



## Attachment Kit: P/N 08E55-S3Y-100

Security system harness

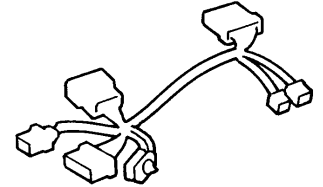

Control unit bracket

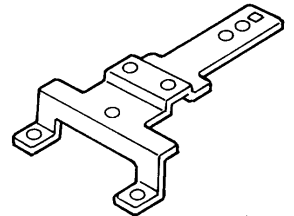

Wire tie with clip

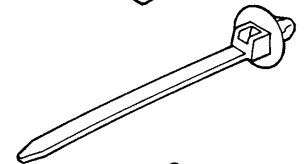

Relay

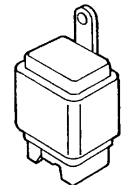

Flange bolt, 6 mm



Flange nut, 6 mm



2 Long wire ties

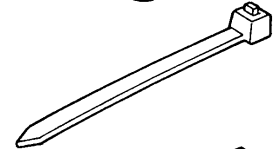

2 Short wire ties

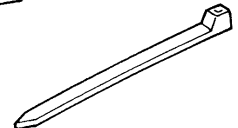

Cushion tape

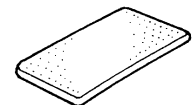

Fuse label

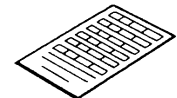

## TOOLS AND SUPPLIES REQUIRED

Small flat-tip screwdriver  
#2 Phillips screwdriver  
10 mm Combination wrench  
Eye protection (face shield, safety goggles, etc.)  
Center punch  
Drill  
3 mm, 5.5 mm, and 12 mm Drill bits  
Torque wrench  
File  
Felt-tip pen  
Ratchet  
10 mm Sockets  
Tape measure  
Diagonal cutters

### Adjusting the Control Unit

Use a small flat-tip screwdriver to change the mode switch, the horn/siren switch, and to adjust the sensitivity. The horn/siren switch must be set in the "HORN" position.

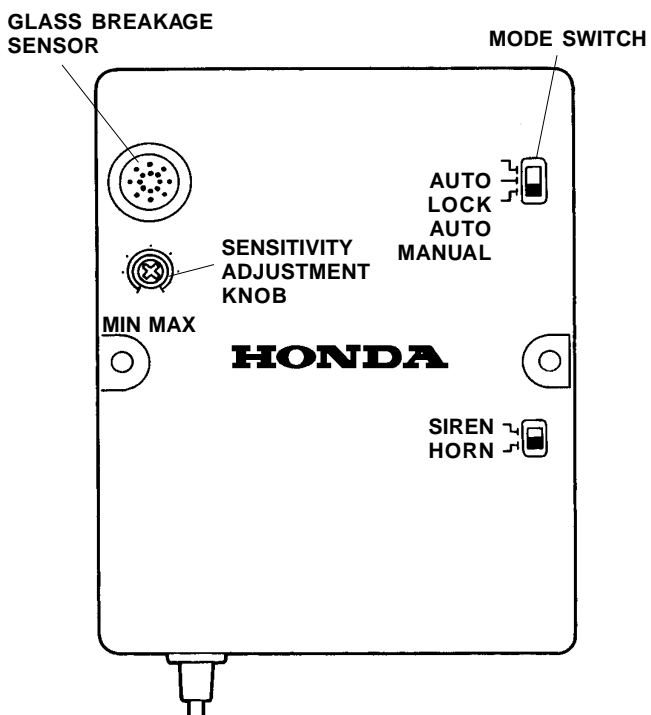

#### Mode Switch:

- Set the mode switch according to the customer's choice.
- Refer to the Owner's Manual for the explanation of each mode.

#### Glass Breakage Sensor:

Do not attach anything like scotch tape over the holes; this is a microphone pickup.

#### Sensitivity Adjustment Knob:

- Adjust the sensitivity only if the customer requests it; the sensitivity adjustment of the glass breakage sensor is factory-set.
- Be careful when you adjust the sensitivity; if you raise the sensitivity too much, the security system can give a false alarm. If the sensitivity is too low, the security system may not work, even if glass is broken.

## INSTALLATION

**Customer Information:** The information in this installation instruction is intended for use only by skilled technicians who have the proper tools, equipment, and training to correctly and safely add equipment to your car. These procedures should not be attempted by "do-it-yourselfers."

1. Write down the frequencies for the radio station preset buttons.
2. Disconnect the negative cable from the battery.
3. Using a small flat-tip screwdriver, gently remove the two blank covers. Be careful not to damage the dashboard.

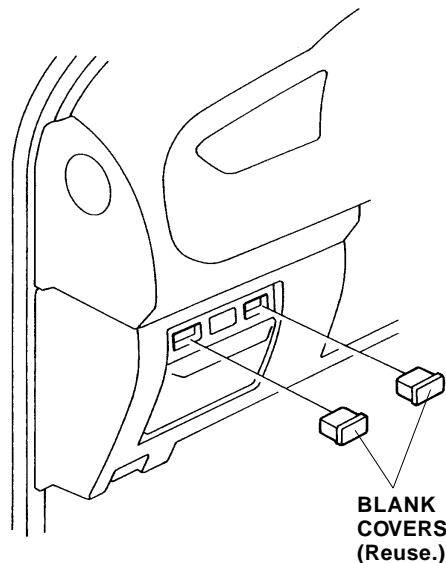

4. Remove the pocket by lifting it up toward you.

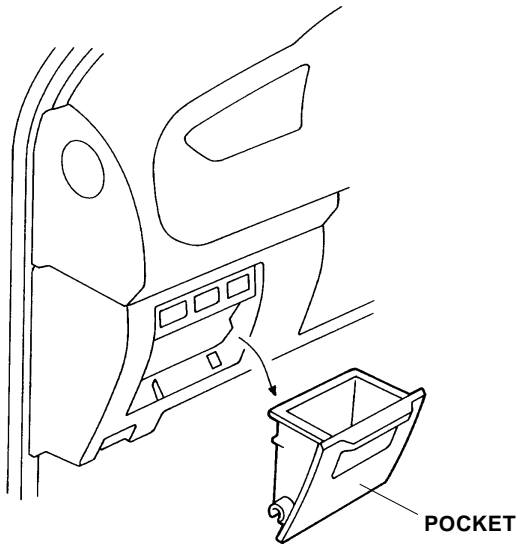

5. Remove the keyless entry control unit (two bolts, and unplug the connector).

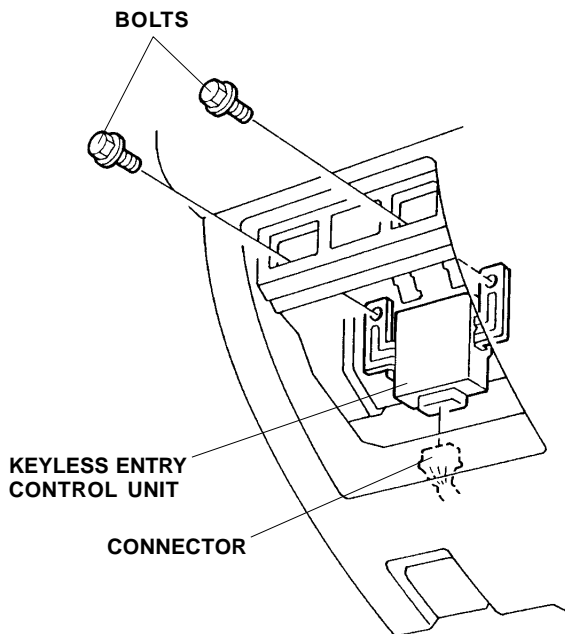

6. Get the control unit bracket and relay. Install the relay on the control unit bracket (one 6 mm flange bolt and one 6 mm flange nut). Tighten securely.

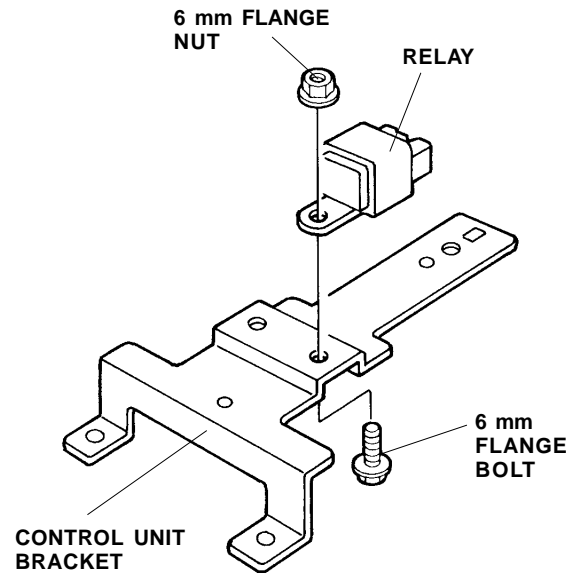

7. Install the control unit on the control unit bracket (two 4 x 30 mm washer-screws).

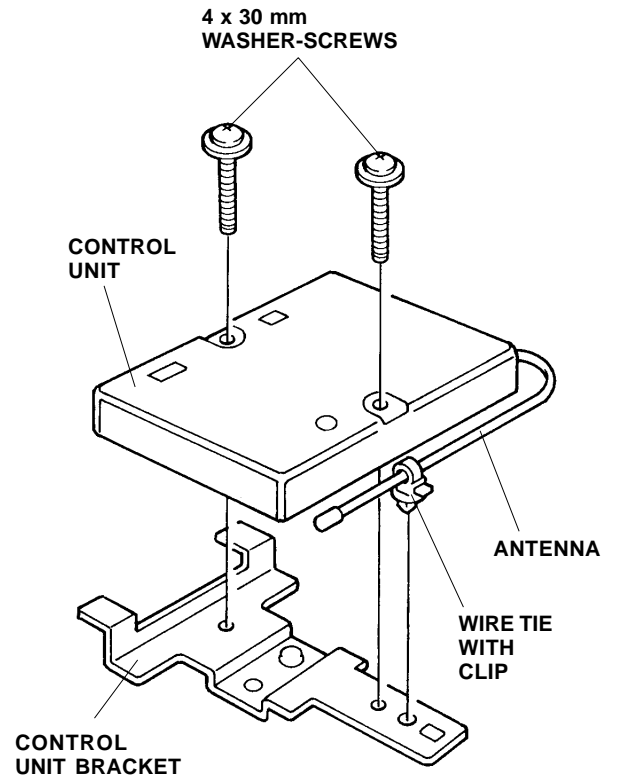

8. Attach the wire tie with clip to the antenna of the control unit, then push the clip into the hole in the control unit bracket. Cut off the excess wire tie.

- Turn the keyless entry control unit around from its original position, and mount the control unit bracket and keyless entry control unit using the two bolts you removed in step 5.

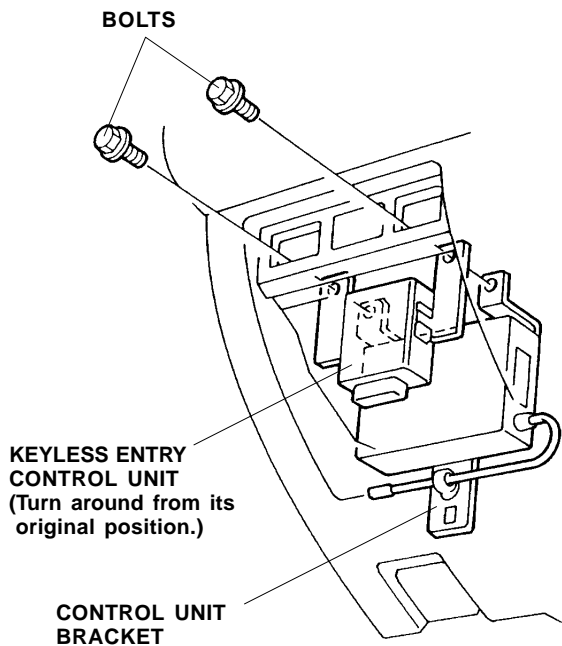

- Remove the lower steering column cover (three screws and six clips). Use a shop towel around a small flat-tip screwdriver to release the six retaining clips.

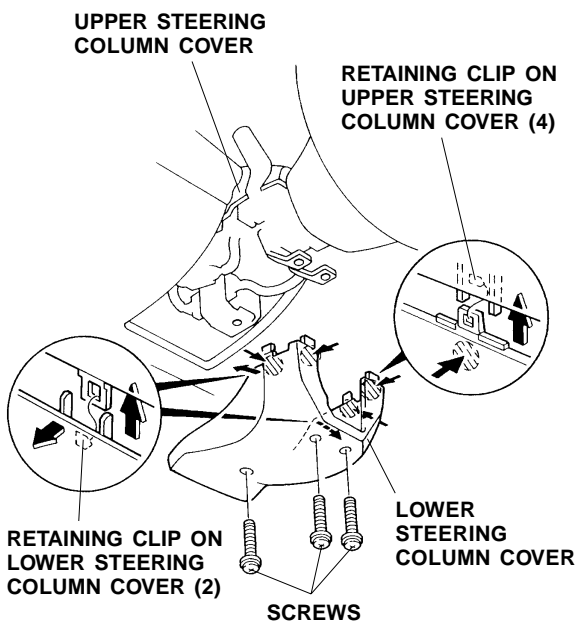

- Loosen the four flange nuts that secure the steering column bracket, and lower the steering column. Do not remove the flange nuts.

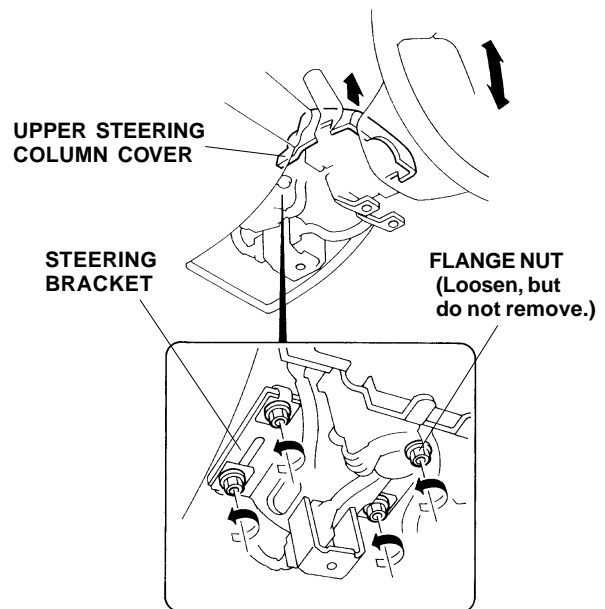

- Remove the upper steering column cover by rocking the steering column up and down as required.
- Measure and mark the left side of the lower steering column cover.

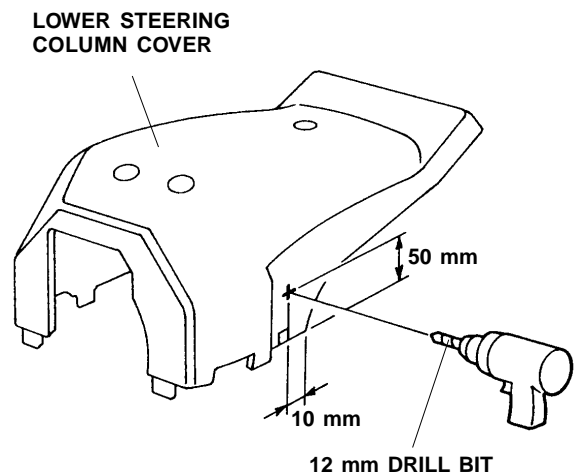

- While wearing eye protection, lightly center-punch the mark, and drill a 12 mm hole:
  - First drill a pilot hole with a 3 mm bit, then finish with a 12 mm bit.
  - Remove all burrs.

- Route the terminal ends of the disarm switch through the hole you just drilled in the lower steering column cover, and secure the disarm switch with the washer and the 12 mm nut from the kit.

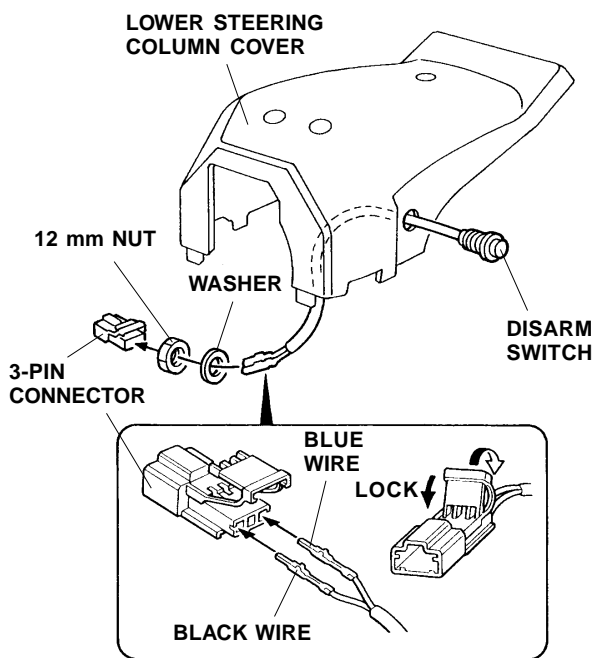

- Get the 3-pin connector included in the kit. Firmly push the disarm switch terminals into the 3-pin connector until they click into position, then lower the lock.
- Measure and mark the inside of the upper steering column cover.

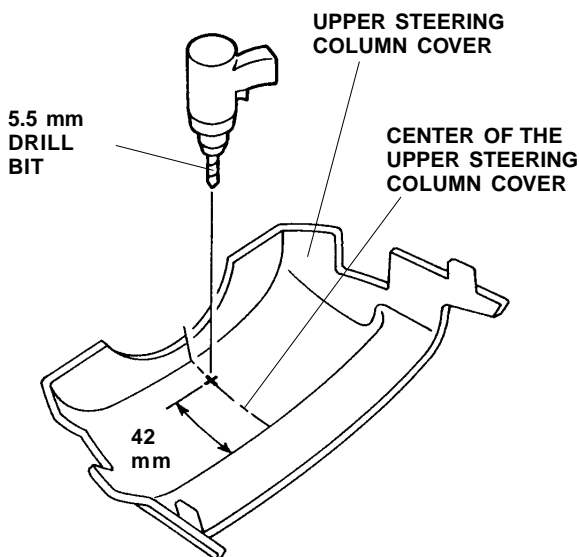

- While wearing eye protection, lightly center-punch the mark, and drill a 5.5 mm hole through the center-punched mark. Remove all burrs.

- Route the terminal ends of the LED through the hole you just drilled in the upper steering column cover, and secure the LED with the push nut. Install the push nut securely.

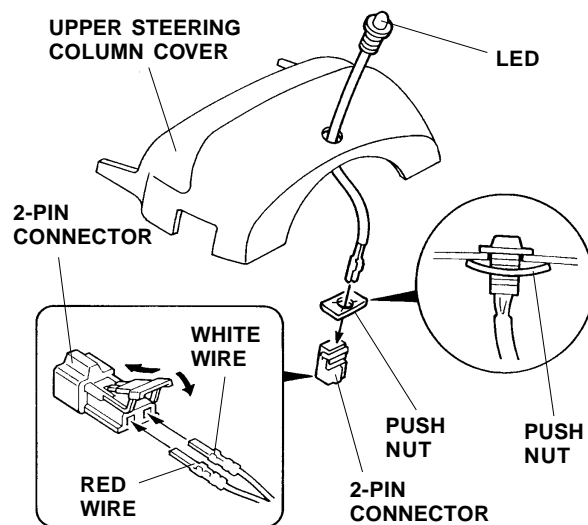

- Get the 2-pin connector included in the kit. Firmly push the LED terminals into the 2-pin connector until they click into position, then lower the lock.
- Reinstall the upper steering column cover with the 2-pin connector on the left side of the steering wheel. Rock the steering column up and down as required for access.

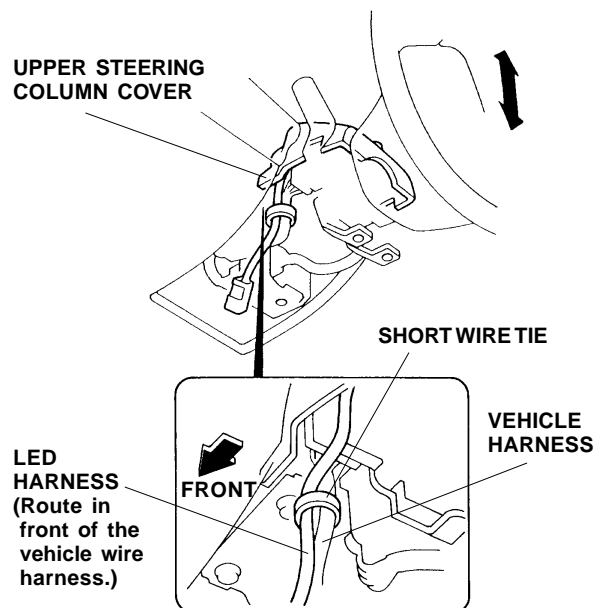

- Secure the LED harness to the vehicle harness with one short wire tie. Cut off the excess wire tie.

23. Torque the four flange nuts you loosened in step 11 to 10 to 16 N·m (7 to 12 lb-ft).

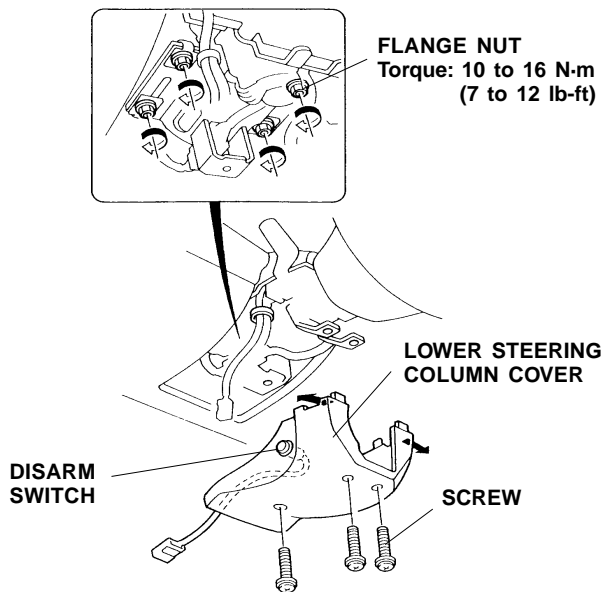

24. Reinstall the lower steering column cover by spreading the cover open to avoid breaking the disarm switch. Reinstall the three screws.
25. Attach the two fuse labels to the fuse case on the security system harness, then push the clip of the fuse case into the hole in the control unit bracket.

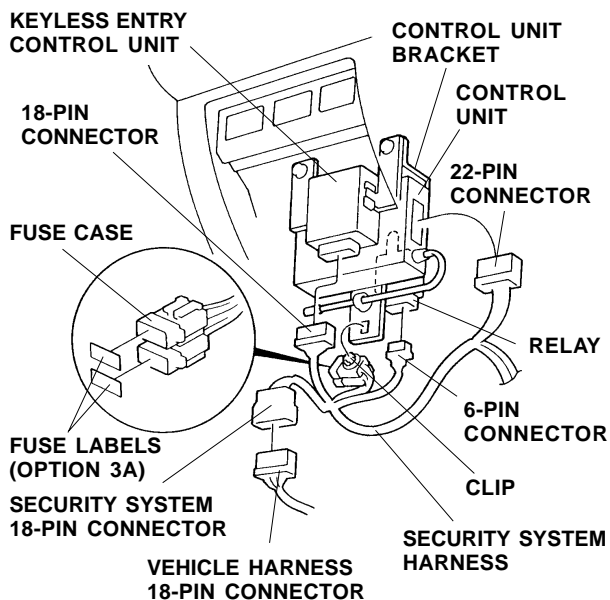

26. Plug the 6-pin connector of the security system harness into the relay you installed in step 6.
27. Plug the 18-pin connector of the security system harness in between the keyless entry control unit and the vehicle 18-pin connector.
28. Plug the 22-pin connector of the security system harness into the control unit.

29. Connect the disarm switch and LED harness connectors to the 2-pin and 3-pin connectors of the security system harness.

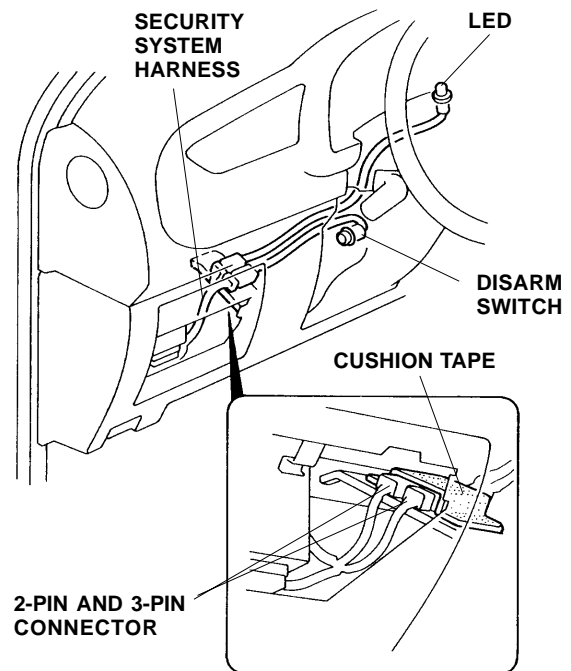

30. Secure the 2-pin and 3-pin connectors to the knee bolster with the cushion tape in the area shown.
31. Secure the security system harness to the vehicle harness with two long wire ties and one short wire tie.

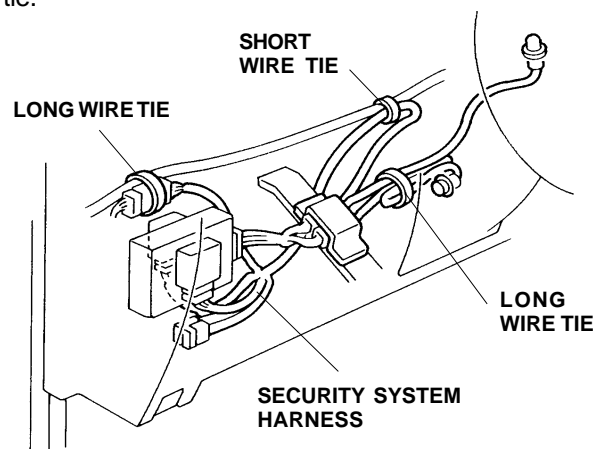

32. Check that all wire harnesses are routed properly and all connectors are plugged in.
33. Reinstall the pocket and the switch covers.
34. Reconnect the negative cable to the battery, and reset the radio station presets.
35. Check the operation of the security system as described in the Owner's Manual supplied.
- NOTE: The remotes that came with the vehicle will not arm the security system; use the new remotes included with the security system.