



Transport and preliminary information

StoraXe PowerBooster

Compact Storage System

GSS0608



Table of Contents

Table of Contents	2
1 <u>Transport information</u>	3
2 <u>Installation information</u>	4
3 <u>Requirements regarding installation location</u>	6
3.1.1 Environmental conditions	6
3.1.2 Requirements regarding installation location	6
4 <u>Technical data</u>	8
5 <u>Temporary storage of the battery modules</u>	9
6 <u>Base drawing</u>	10
7 <u>Checklist for commissioning</u>	11
8 <u>Contact</u>	13
8.1 Support ADS-TEC	13
8.2 Company address	13
9 <u>Appendix: Extract of the electrical diagram</u>	14

1 Transport information

(Detail from the instruction manual)

The battery modules are declared as dangerous goods when transported. Follow the relevant instructions on the packaging.

The storage system is delivered in 3 parts:

- One pallet with storage system preassembled, without battery modules (approx. 800 kg gross).
- Two pallets with 2x 4 battery modules, corresponding power and communication cables and manual (2x 330 kg gross).

CAUTION



Risk of irreversible damage to the components!

Improper transport can irreversibly damage components.

- ➔ Use only means of transport that are designed for the weight of the storage system and battery modules.
- ➔ Transport the battery modules to the final location separately from the storage system.
- ➔ Transport the storage system upright with the help of a forklift to the final location.
- ➔ Bear in mind that the centre of gravity of the storage system is not positioned centrally.
- ➔ Move the storage system only when in a lifted state.
- ➔ Use non-slip mats on any surfaces where the storage system will have to be set down temporarily.

WARNING



Hazard from heavy loads!

If the storage system or the battery modules tip over or fall, they can cause serious injuries.

- ➔ Hazard from falling or tipping loads.
- ➔ Risk of crushing hands and feet during transport.

2 Installation information

(Detail from the information of the housing manufacturer – German/English/French)

BLENDEN ENTFERNEN - PLINTH REMOVE - ENLEVER LES BANDEAUX

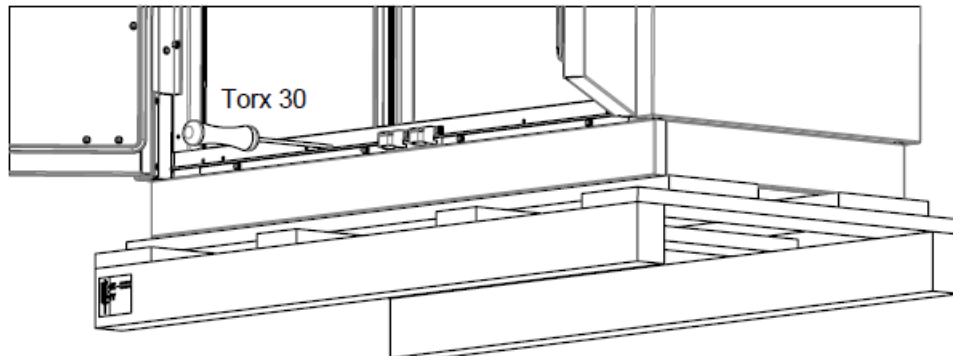

- 1 Die front Blende Befestigung Schrauben raus drehen
Unscrew the front plinth fixing screws
Dévisser les vis de fixation du bandeau avant

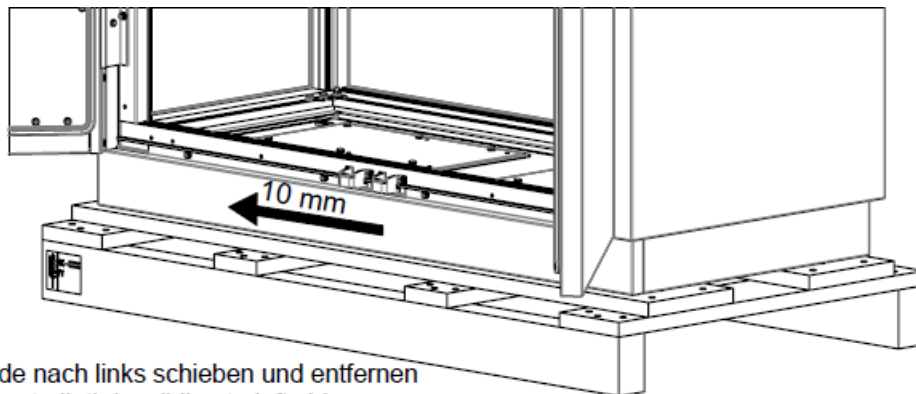

- 2 Die front Blende nach links schieben und entfernen
Remove the front plinth by sliding to left side
Glisser le bandeau frontal vers la gauche

- 3 Die Seite Blenden nach vorne schieben und entfernen
Remove the side plinth by sliding to front side
Glisser les bandeaux vers l'avant

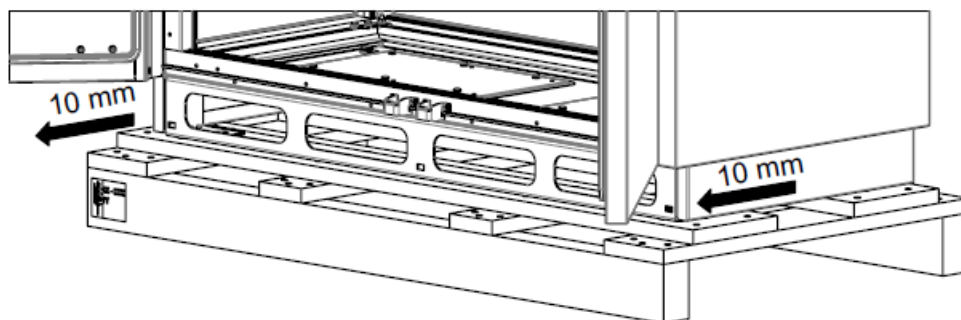

PALETTE ENTFERNEN - PALLET REMOVE - ENLEVER LA PALETTE

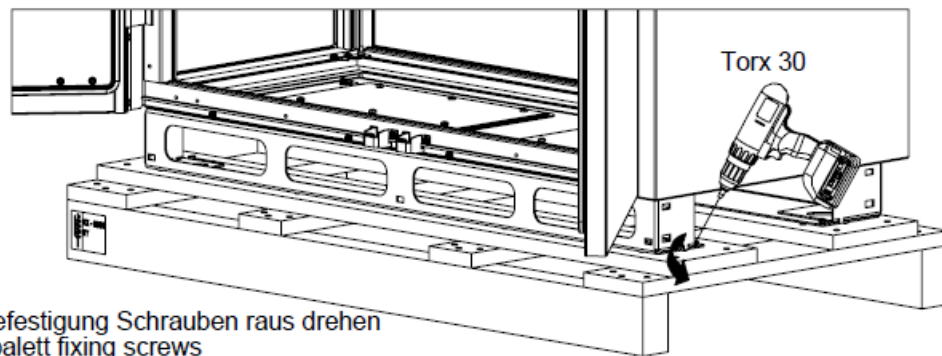

Die 4 Palette Befestigung Schrauben raus drehen
Remove the 4 pallet fixing screws
Dévisser les 4 vis de fixation sur la palette

3 Requirements regarding installation location

(Detail from the instruction manual)

The system is designed for stationary use in an outdoor area. Make certain that the specified environmental conditions are maintained at all times. Use in non-specified environments, e.g. on board ships, in explosive atmospheres or at high altitude (see the climatic environmental conditions) is prohibited.

CAUTION



Hazard due to condensation!

- Condensation may form if the system has not had sufficient time to settle to the environmental conditions following transport or before it is put into operation again. (Connection to AC supply is required.)

3.1.1 Environmental conditions

Observe the environmental conditions information in the technical data (⇒ 4 *Technical data*).

3.1.2 Requirements regarding installation location

Please note that the battery system may not be set up and operated

- in buildings, garages, courtyards and other covered structures
- in areas where there is a risk of flooding
- in areas where there is a risk of fire and explosion
- in the vicinity of combustible materials
- and in areas with sandstorms
- in permanent residential areas
- in the vicinity of escape routes

Installation conditions:

- The "Commissioning requirements" checklist must be completed and signed (⇒ 7 *Checklist for commissioning*).
- The system is only suitable for outdoor installation.
- Observe the following floor space requirements for the system:
 - The floor space is to be constructed at the installation location in accordance with the local conditions and technical data (⇒ 4 *Technical data*)
 - The floor space is exactly horizontal.
 - Cable entry is from below.
 - The floor space has the required load capacity for the 1.25 t weight of the system and has to withstand this load permanently.
If applicable, also take into account the weight of the means of transport.
 - Sufficient drainage is available.
- Earthing via ring earth electrode for flexible connection cable (min. 16 mm²) according to national and local regulations and conditions must be in place.
- Note that ventilation openings must be kept clear.
 - The air at the ventilation openings must be able to circulate freely.
 - During the entire operating time, no leaves, dirt, etc. must be sucked in from the ventilation openings.
- Protect the system against penetrating water (groundwater or flood hazard area).
- Keep the existing housing doors closed.

- Observe the required minimum distances of 1.5 m to adjacent structures. Make additional spacing allowances for open doors and any escape routes.

When installing in built-up areas, observe the local noise abatement regulations (Germany: "Technische Anleitung zum Schutz gegen Lärm" (Technical Instructions for Protection against Noise), abbreviated "TA Lärm"). Observe the resulting minimum distances to residential buildings.

Power connections:

Observe the information given in the electrical diagram (➔ 9 Appendix: *Electrical diagram*).

4 Technical data

		GSS0608
System	System type	AC coupled storage system with outdoor cabinet
	Control / functions	ADS-TEC Energy apps: peak-shaving, optimisation of personal consumption, ADS-TEC master interface
	Network connection	Ethernet, RJ45, LTE
	Inverter	Integrated
Grid connection	Effective power	60 kW
	Apparent power	60 kVA
	Mains voltage	400 VAC
	Grid type	TN-S with 3Ph + N + PE (stationary)
	Grid frequency	50 Hz
Battery storage system	Battery technology	Lithium-ion
	Nominal energy content	84,6 kWh
Battery cells²	Cell chemistry	Lithium-NMC
General data	Installation location	Outdoor
	Temperature range	-20 °C to +40 °C
	Protection class	IP55
	Guarantee of current market value (battery cells)	Up to 10 years (in combination with BatX)
	Vandalism class	IK10
	Dimensions WxHxD	1430 x 2500 x 940 mm (+/-20 mm)
	Weight	Approx. 1,250 kg (fully equipped)
Standards	List of the applied harmonised standards	Wireless ETSI EN 301 908-1 V13.1.1; ETSI EN 301 908-13 V13.1.1 EMC ETSI EN 301 489-1 V2.2.3; EN 61000-6-2:2005; EN 61000-6-3:2021 Safety EN 62368-1:2014 + AC:2015; EN 62311:2008; EN 61439-1:2011
	List of the applied regulations, standards and applications	EMC ETSI EN 301 489-52 V1.1.0 Safety EN IEC 61439-7:2020; IEC 62485-5:2020; EN 62619:2017 Functional safety EN 61508 series ed. 2 Miscellaneous VDE-AR-E 2510-2:2021 UN 38.3 Revision 7:2019 (on battery module layer!)

5 Temporary storage of the battery modules

Observe the manufacturer specifications and safety data sheets of the battery cell.

- It is strongly advised that directive VDS-3103: 2019-06 also be observed.
- Store the battery modules in their original packaging in a dry, ideally air-conditioned indoor space until installed.
- Avoid direct sunlight, large temperature fluctuations and frost.

CAUTION



Damage to property due to incorrect storage!

- ➔ Store the battery modules properly in the original packaging until installation according to the information in the battery module data sheet.
- ➔ No direct sunlight, no large temperature fluctuations, no frost.
- ➔ Storage temperature: 0 to + 40°C.
- ➔ Avoid condensation.
Condensation can occur if the battery module has not been sufficiently climatically adjusted after transport or before installation.

6 Base drawing

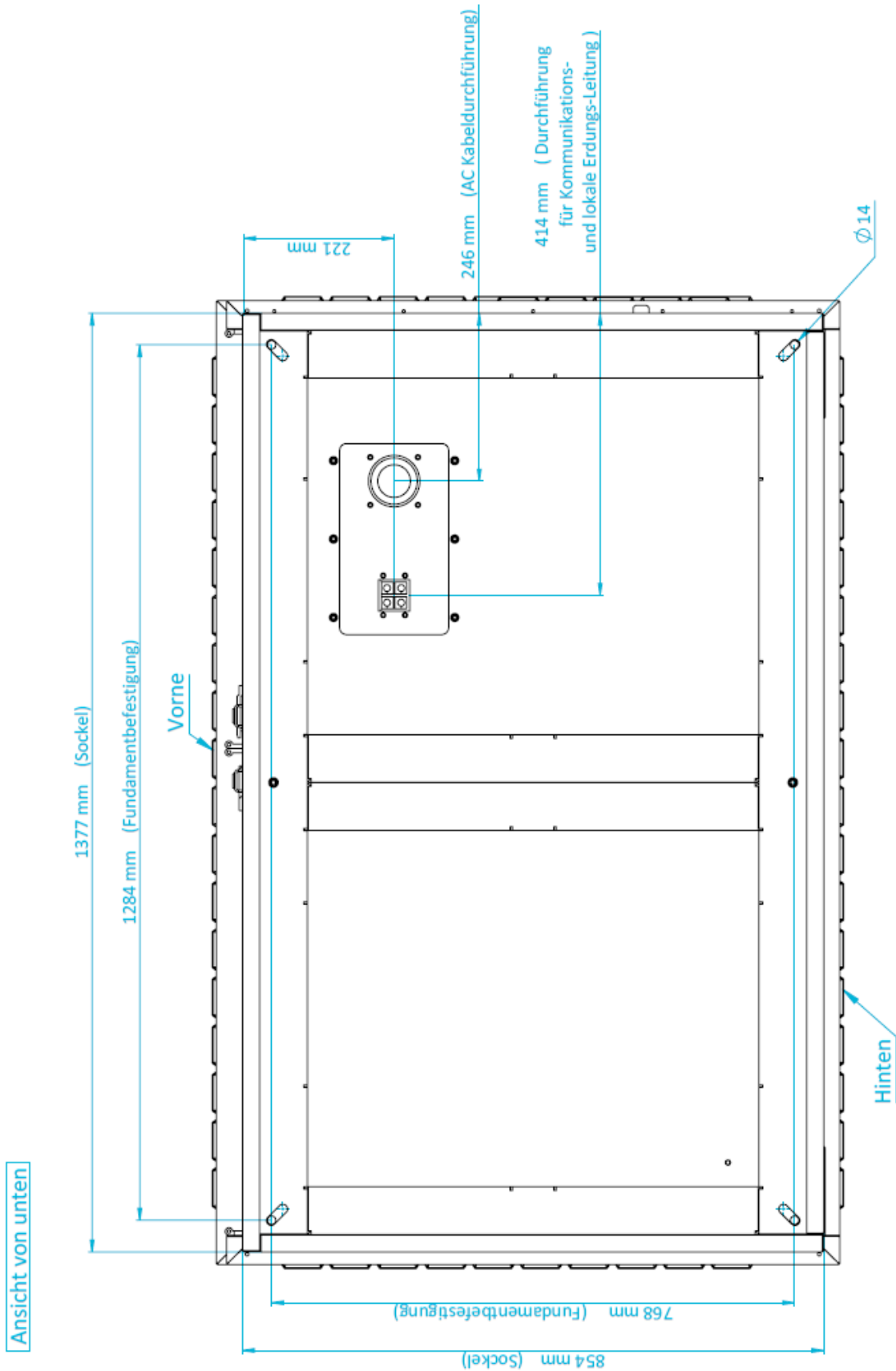

7 Checklist for commissioning

Checklist: Commissioning requirements for GSS storage system

Please send this filled out checklist to support-est@ads-tec-energy.com at least 10 working days before the planned commissioning.

Project name:	<input type="text"/>	Order number:	<input type="text"/>
Client:	<input type="text"/>	Contact person:	<input type="text"/>
Commissioning date:	<input type="text"/>	Telephone/mobile:	<input type="text"/>
		E-mail:	<input type="text"/>

Client address:	<input type="text"/>	Plant location (if different):	<input type="text"/>
-----------------	----------------------	--------------------------------	----------------------

1) Before delivery and commissioning	OK	nOK	Comment
Attachment points for the storage system prepared according to base drawing			
Earthing via ring earth electrode for flexible connection cable available			
Door stop and swivel range taken into account			
Safety distances (fire protection) taken into account			
Protection against penetrating water (groundwater or flood hazard area) taken into account			
Ventilation openings and their 1.5 m unobstructed ventilation around the storage system taken into account			
Routing of AC power supply to the transfer point carried out according to electrical diagram			
AC power supply connected on the grid side. Grid side fused according to the requirement in the electrical diagram.			
SIM cards (4G/LTE) and local Ethernet connection for communication / control / monitoring available			
Customer-specific: additional meters / smart meters for installation during commissioning are available			
Only for Master mode: Software / control solution available			
Connection permission obtained from the local network operator			
Requirements/permission for charging / discharging from/into the grid during commissioning obtained			

2) Delivery and installation at the plant location	OK	nOK	Comment
Installation at system location organised by forklift (GSS) or crane (battery modules). Information in the transport drawing taken into account.			
Access possible for trucks to the plant location.			
Necessary road closure for crane / truck during unloading approved.			
Access to the plant location provided for the logistics and commissioning personnel.			
3) Day of commissioning	OK	nOK	Comment
On the day of commissioning at the plant location, authorised electricians are charged with connecting and checking the cabling in accordance with DIN VDE 0100-800 (including protocol)			
Grid test: Rotating field right and loop check <0.3 Ohm			
Switching authorisation for power and auxiliary voltage supply assigned on day of commissioning The person authorised for switching is on site.			
Customer-specific: additional meters / smart meters for commissioning are installed and ready for operation			
Customer-specific: external control for testing the charging / discharging process is functional and the test can be carried out			
Customer-specific: SIM card (LTE) / local Ethernet Internet connection connected and communication possible			
The customer's qualified personnel for operational handover with instruction is available at the plant site on the day of commissioning			

Additional comments / notes:

Location	Date	Name in block letters	Signature
-----------------	-------------	------------------------------	------------------

My signature confirms that the necessary prerequisites for the installation and commissioning of the Powerbooster battery storage system have been professionally created. ads-tec assumes no liability for any costs resulting from failure to comply during delivery, installation and commissioning as well as during subsequent operation.

8 Contact

8.1 Support ADS-TEC

The ADS-TEC support team is available for inquiries from direct customers between 8:30am and 5:00pm, Monday to Friday. The support team can be reached via phone or e-mail:

Phone: +49 7022 2522-203

Email: support.est@ads-tec-energy.com

Alternatively, you can contact us by completing a support form on our website www.adstec-energy.com. Our Support team will then get in touch with you as soon as possible.

8.2 Company address

ads-tec Energy GmbH
Heinrich-Hertz-Str.1
72622 Nürtingen
Germany

Phone: +49 7022 2522-201

Email: energy-storage@ads-tec-energy.com

Home: www.adstec-energy.com

