

Cylinder Head - All Models Except PZEV

Cylinder Head

Special Tools	6-2
Component Location Index	6-3
Engine Compression Inspection	6-6
VTEC Rocker Arm Test	6-7
VTC Actuator Inspection	6-8
Valve Clearance Adjustment	6-9
Crankshaft Pulley Removal and Installation	6-12
Cam Chain Removal	6-13
Cam Chain Installation	6-15
Cam Chain Auto-tensioner Removal and Installation	6-20
Cam Chain Case Oil Seal Installation	6-22
Cam Chain Inspection	6-23
Cylinder Head Cover Removal	6-24
Cylinder Head Cover Installation	6-25
Cylinder Head Removal	6-27
CMP Pulse Plate A Replacement	6-29
CMP Pulse Plate B Replacement	6-30
VTC Actuator, Exhaust Camshaft Sprocket Replacement	6-30
Cylinder Head Inspection for Warp	6-31
Rocker Arm Assembly Removal	6-32
Rocker Arm and Shaft Disassembly/Reassembly	6-33
Rocker Arm and Shaft Inspection	6-34
Camshaft Inspection	6-35
Valve, Spring, and Valve Seal Removal	6-37
Valve Inspection	6-38
Valve Stem-to-Guide Clearance Inspection	6-38
Valve Guide Replacement	6-39
Valve Seat Reconditioning	6-41
Valve, Spring, and Valve Seal Installation	6-42
Rocker Arm Assembly Installation	6-43
Cylinder Head Installation	6-44
Sealing Bolt Installation	6-48

Cylinder Head

Special Tools

Ref.No.	Tool Number	Description	Qty
①	07742-0010100	Valve Guide Driver, 5.35 x 9.7 mm	1
②	07746-0010400	Attachment, 52 x 55 mm	1
③	07749-0010000	Driver Handle, 15 x 135L	1
④	07757-PJ1010A	Valve Spring Compressor Attachment	1
⑤	07AAB-RJAA100	Crankshaft Pulley Holder	1
⑥	07AAB-RWCA120	Camshaft Lock Pin Set	1
⑦	07AAJ-PNAA101	Air Pressure Regulator	1
⑧	07AAJ-RWCA100	Cam Chain Inspection Gauge	1
⑨	07HAH-PJ7A100	Valve Guide Reamer, 5.5 mm	1
⑩	07JAA-001020A	Socket, 19 mm	1
⑪	07JAB-001020B	Handle, 6-25-660L	1
⑫	07MAA-PR70110	Adjuster	1
⑬	07MAA-PR70120	Locknut Wrench	1
⑭	07PAD-0010000	Stem Seal Driver, 30 mm	1
⑮	07ZAJ-PNAA101	VTEC Air Adapter	2
⑯	07ZAJ-PNAA200	VTEC Air Stopper	1
⑰	07ZAJ-PNAA300	Air Joint Adapter	1

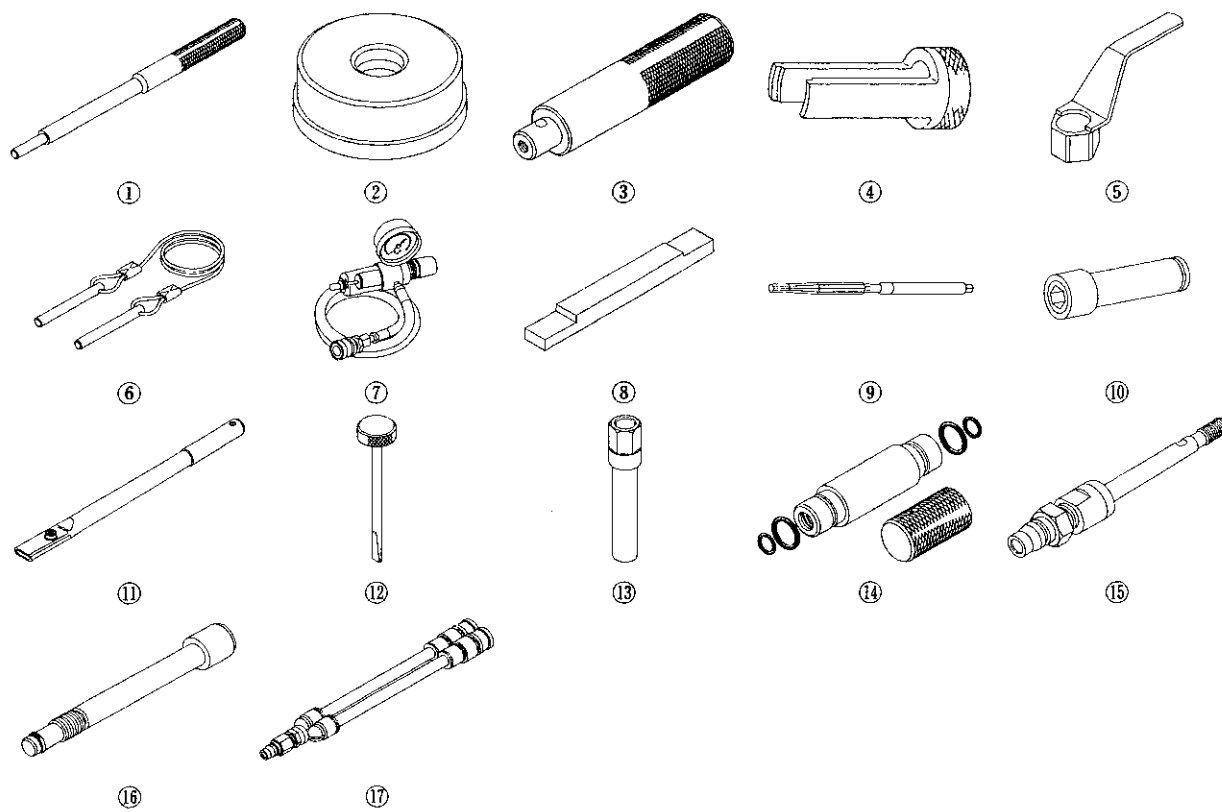



Component Location Index

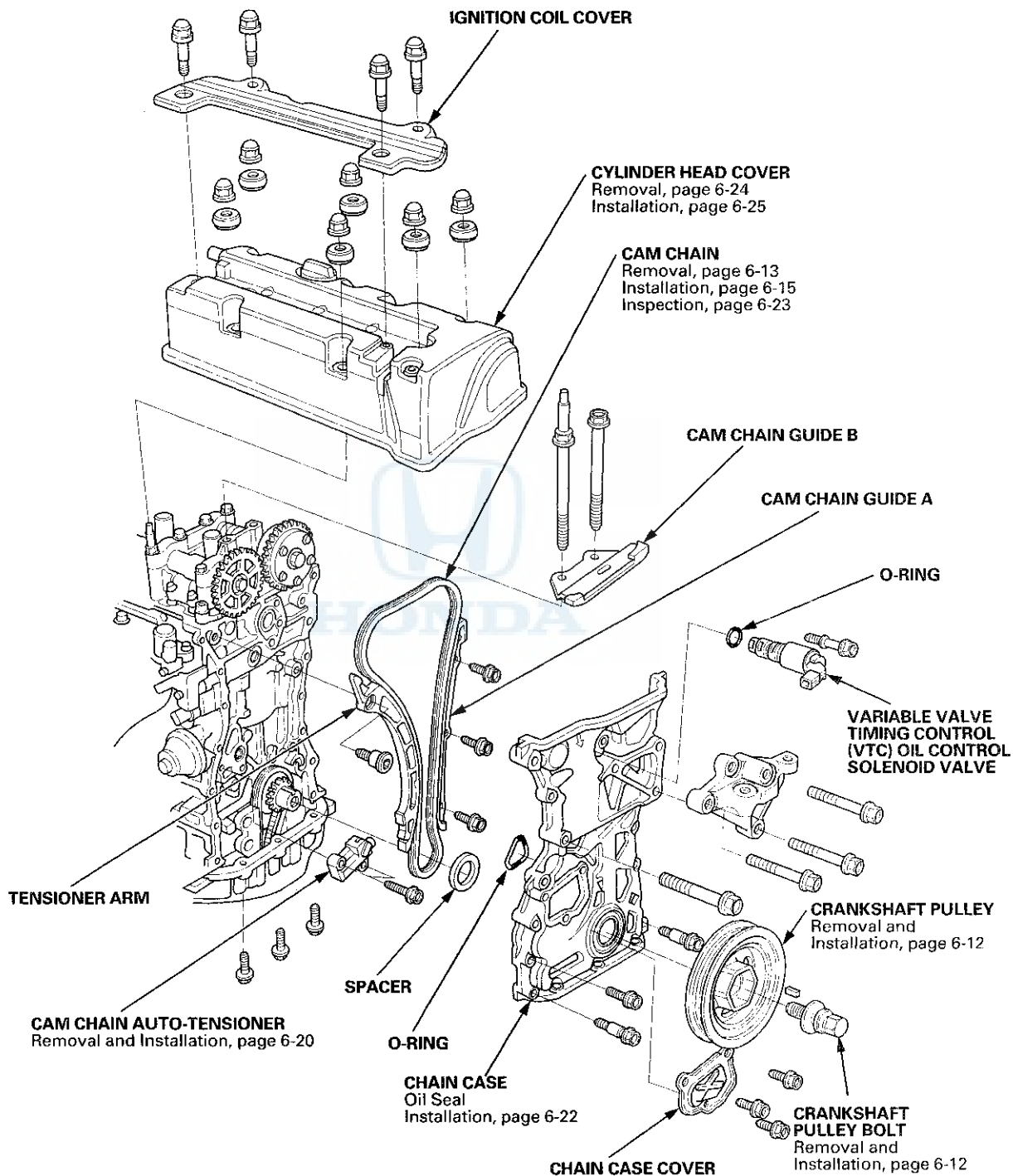

(cont'd)

Cylinder Head

Component Location Index (cont'd)

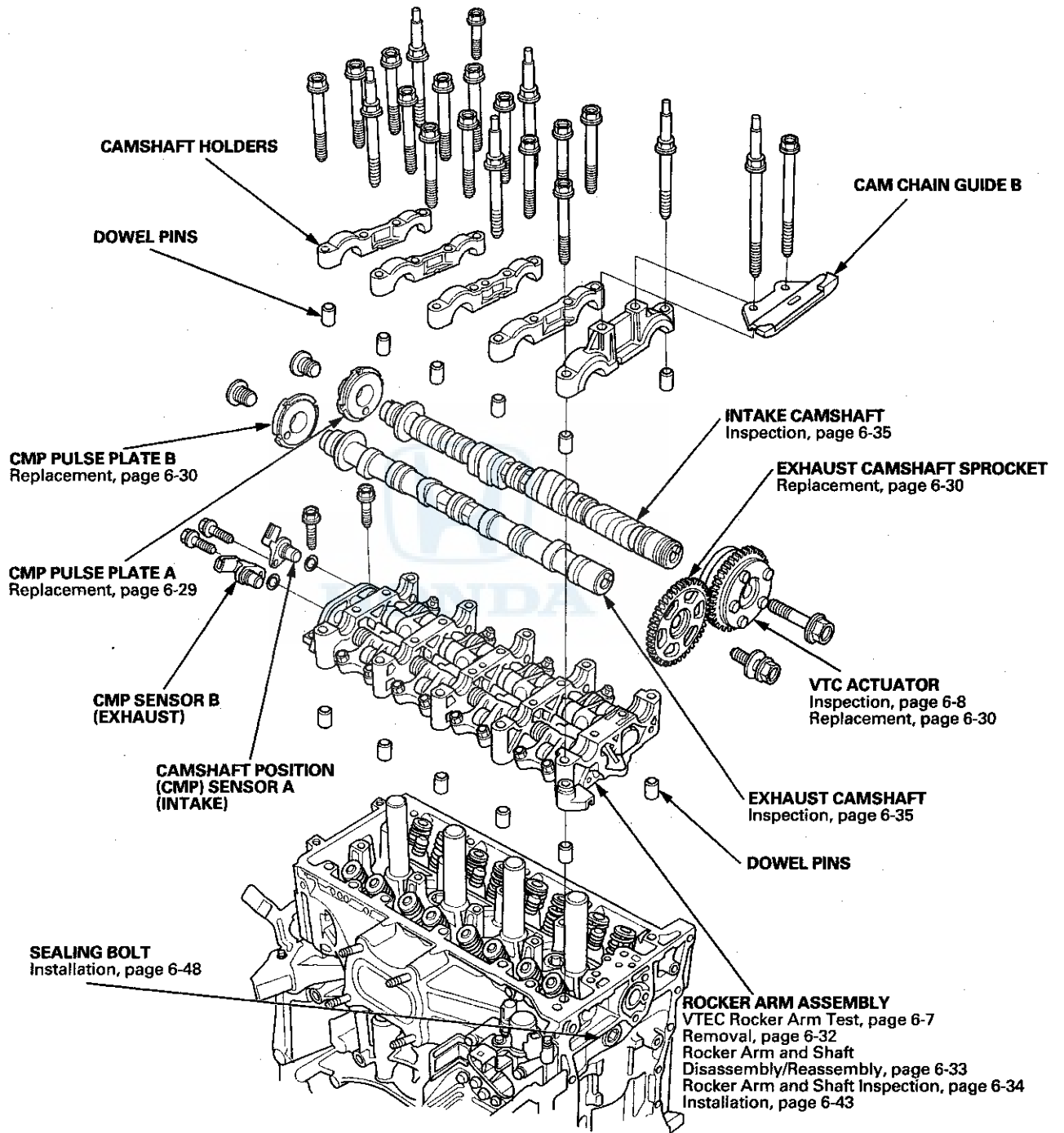

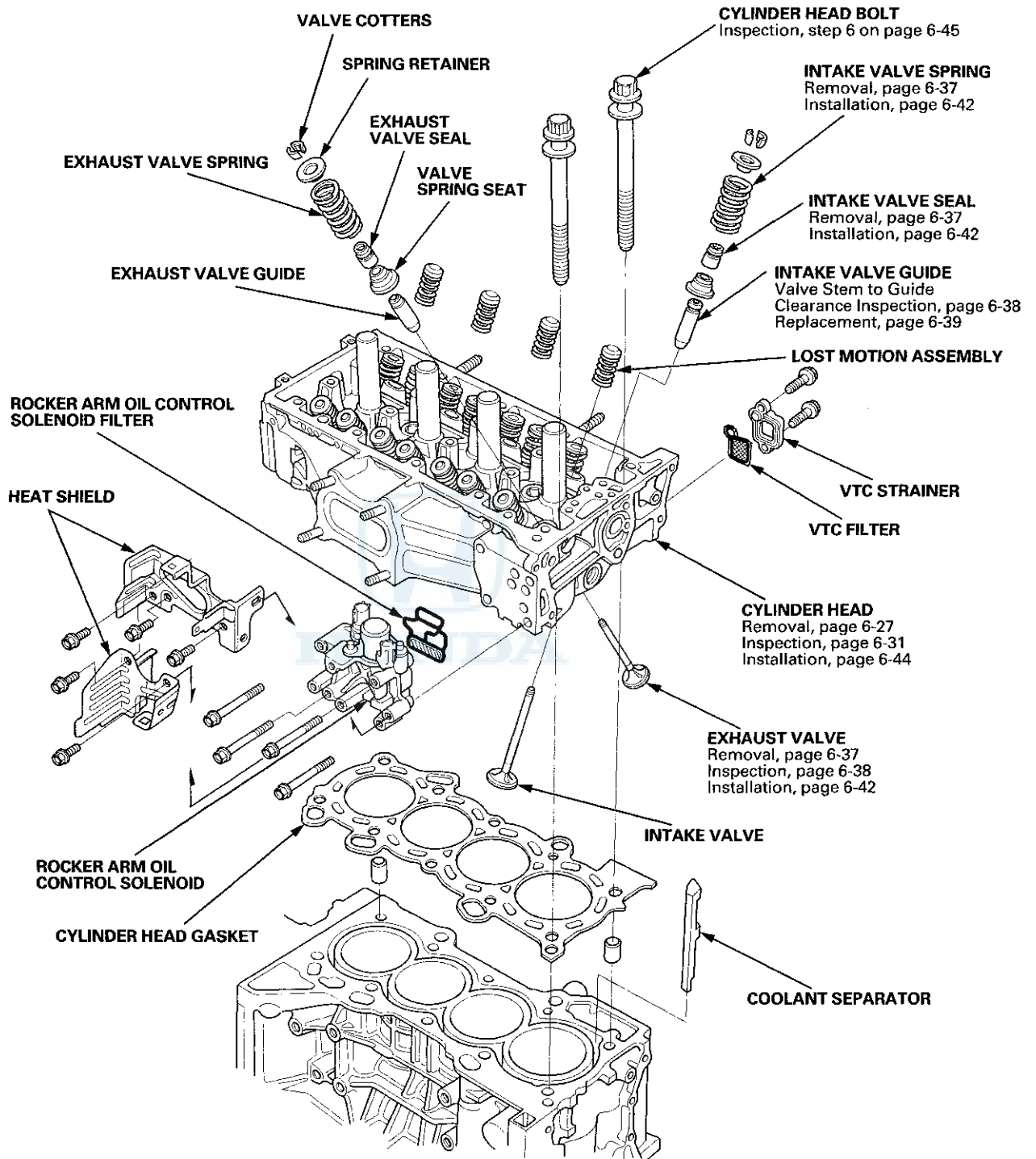

Cylinder Head

Engine Compression Inspection

NOTE: After this inspection, you must reset the engine control module (ECM)/powertrain control module (PCM), otherwise the ECM/PCM will continue to stop the fuel injectors from operating.

1. Warm up the engine to normal operating temperature (cooling fan comes on).
2. Turn the ignition switch to LOCK (0).
3. Connect the Honda Diagnostic System (HDS) to the data link connector (DLC) (see step 2 on page 11-3).
4. Turn the ignition switch to ON (II).
5. Make sure the HDS communicates with the vehicle and the ECM/PCM. If it does not communicate, troubleshoot the DLC circuit (see page 11-181).
6. Select ALL INJECTORS STOP in the PGM-FI, INSPECTION menu with the HDS.
7. Turn the ignition switch to LOCK (0).
8. Remove the four ignition coils (see page 4-20).
9. Remove the four spark plugs (see page 4-20).
10. Attach a compression gauge to the spark plug hole.

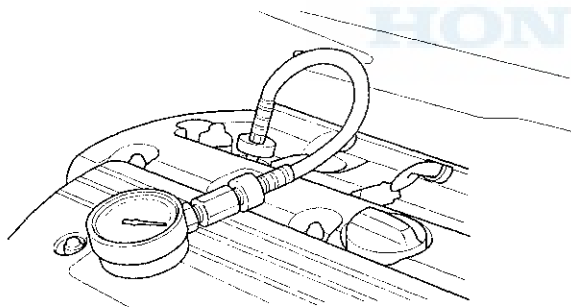

11. Step on the accelerator pedal to open the throttle fully, then crank the engine with the starter motor, and measure the compression.

Compression Pressure:
Above 932 kPa (9.5 kgf/cm², 135 psi)

12. Measure the compression on the remaining cylinders.

Maximum Variation:
Within 196 kPa (2.0 kgf/cm², 28 psi)

13. If the compression is not within specifications, check the following items, then remeasure the compression.
 - Incorrect valve clearance
 - Confirmation of cam timing
 - Damaged or worn cam lobes
 - Damaged or worn valves and seats
 - Damaged cylinder head gasket
 - Damaged or worn piston rings
 - Damaged or worn piston and cylinder bore
14. Remove the compression gauge from the spark plug hole.
15. Install the four spark plugs (see page 4-20).
16. Install the four ignition coils (see page 4-20).
17. Select ECM/PCM reset (see page 11-4) in the PGM-FI, INSPECTION menu to cancel ALL INJECTORS STOP with the HDS.



VTEC Rocker Arm Test

Special Tools Required

- VTEC Air Stopper 07ZAJ-PNAA200
- VTEC Air Adapter 07ZAJ-PNAA101 (2)
- Air Joint Adapter 07ZAJ-PNAA300
- Air Pressure Regulator 07AAJ-PNAA101

1. Start the engine, and let it run for 5 minutes, then turn the ignition switch to LOCK (0).
2. Remove the cylinder head cover (see page 6-24).
3. Set the No. 1 piston at top dead center (TDC) (see step 5 on page 6-13).
4. Move the secondary rocker arm (A) for the No. 1 cylinder. The secondary rocker arm should move independently of the mid rocker arm (B).
 - If the secondary rocker arm moves freely, go to step 5.
 - If the secondary rocker arm does not move independently, remove the mid, primary, and secondary rocker arms as an assembly, and check that the pistons in the rocker arms move smoothly. If any rocker arm needs replacing, replace the mid, primary, and secondary rocker arms as an assembly, then retest.

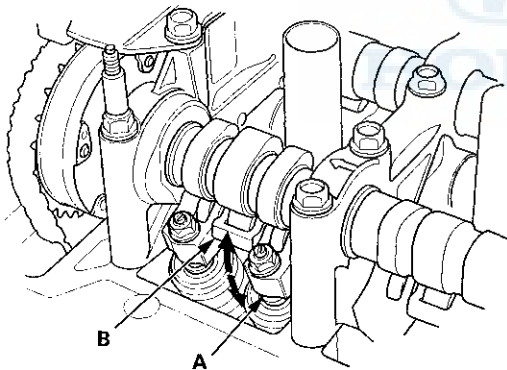

5. Repeat step 4 on the remaining secondary rocker arms with each piston at TDC. When all the secondary rocker arms pass the test, go to step 6.
6. Check that the air pressure on the shop air compressor gauge indicates over 400 kPa (4.0 kgf/cm², 57 psi).
7. Inspect the valve clearance (see page 6-9).
8. Remove the sealing bolt (A) from the relief hole, and install the VTEC air stopper (B).

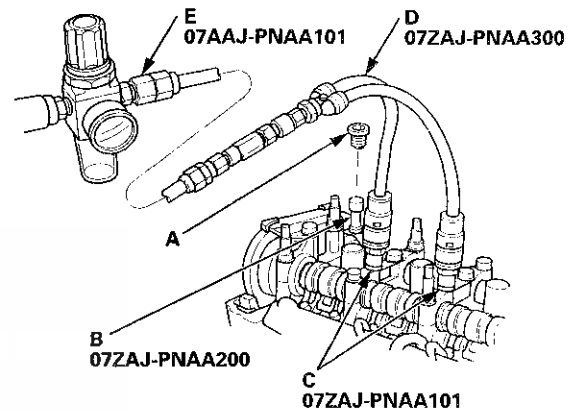

9. Remove the No. 2 and No. 3 camshaft holder bolts, and install the VTEC air adapters (C) finger-tight.
10. Connect the air joint adapter (D) and the air pressure regulator (E).
11. Loosen the valve on the air pressure regulator, and apply the specified air pressure.

Specified Air Pressure:

290 kPa (3.0 kgf/cm², 42 psi)

NOTE: If the rocker arm piston does not move after applying air pressure; move the rocker arm up and down manually by rotating the crankshaft clockwise.

(cont'd)

Cylinder Head

VTEC Rocker Arm Test (cont'd)

12. With the specified air pressure applied, move the secondary rocker arm (A) for the No. 1 cylinder. The mid rocker arm (B), the primary rocker arm (C), and the secondary rocker arm should move together.
 - If the mid, primary, and secondary rocker arms move together, go to step 13.
 - If the mid and primary rocker arms do not move together with the secondary rocker arm, remove the mid, primary, and the secondary rocker arms as an assembly, and check that the pistons in the rocker arms move smoothly. If any rocker arm needs replacing, replace the mid, the primary, and the secondary rocker arms as an assembly, then retest.

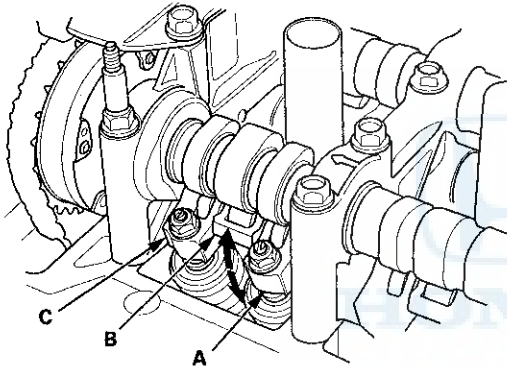

13. Repeat step 12 on the remaining secondary rocker arms with each piston at TDC. When all the secondary rocker arms pass the test, go to step 14.
14. Remove the air pressure regulator, the air joint adapter, the VTEC air adapters, and the VTEC air stopper.
15. Torque the camshaft holder mounting bolts to 22 N·m (2.2 kgf·m, 16 lbf·ft).
16. Torque the sealing bolt to 10 N·m (1.0 kgf·m, 7.4 lbf·ft).
17. Install the cylinder head cover (see page 6-25).

VTC Actuator Inspection

1. Remove the cam chain (see page 6-13).
2. Loosen the rocker arm adjusting screws (see step 2 on page 6-32).
3. Remove the camshaft holder (see step 3 on page 6-32).
4. Remove the intake camshaft.
5. Check that the variable valve timing control (VTC) actuator is locked by turning the VTC actuator counterclockwise. If it is not locked, turn the VTC actuator clockwise until it stops, then recheck it. If it is still not locked, replace the VTC actuator.
6. Seal the retard holes (A) in the No. 1 camshaft journal with tape and a wire tie.

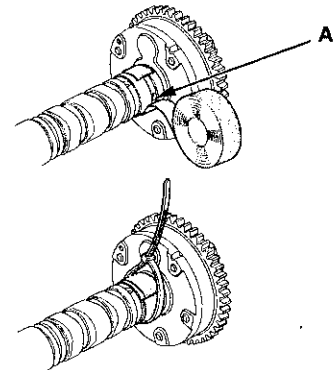

7. Seal one of the advance holes (A) with tape.

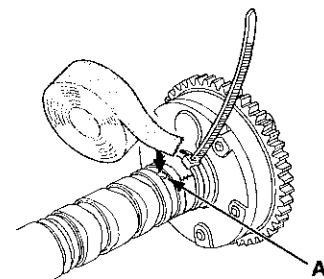



Valve Clearance Adjustment

8. Apply air to the unsealed advance hole to release the lock.

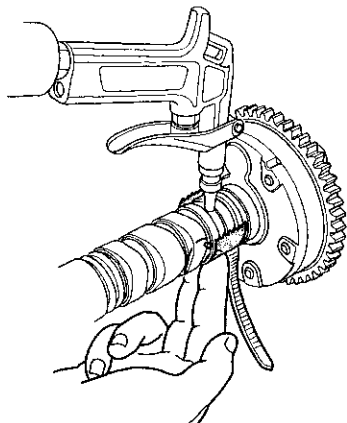

9. Check that the VTC actuator moves smoothly. If the VTC actuator does not move smoothly, replace the VTC actuator.

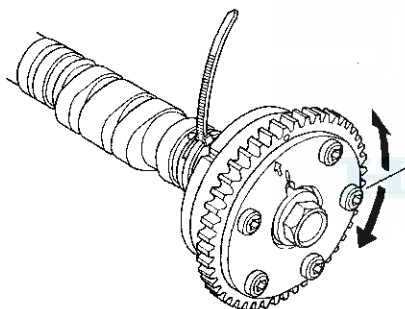

10. Remove the wire tie, the tape, and the adhesive residue from the camshaft journal.
11. Make sure the punch marks on the VTC actuator and the exhaust camshaft sprocket are facing up, then set the camshafts in the cylinder head (see step 7 on page 6-44).
12. Set the camshaft holders and cam chain guide B in place (see step 8 on page 6-44).
13. Tighten the camshaft holder bolts to the specified torque (see step 9 on page 6-44).
14. Hold the camshaft, and turn the VTC actuator clockwise until you hear it click. Make sure to lock the VTC actuator by turning it.
15. Install the cam chain (see page 6-15).
16. Adjust the valve clearance (see page 6-9).

Special Tools Required

- Locknut Wrench 07MAA-PR70120
- Adjuster 07MAA-PR70110

NOTE: Connect the Honda Diagnostic System (HDS) to the data link connector (DLC) and monitor the engine coolant temperature (ECT) sensor 1 with the HDS. Adjust the valve clearance only when the ECT sensor 1 temperature is less than 100 °F (38 °C).

1. Remove the cylinder head cover (see page 6-24).
2. Set the No. 1 piston at top dead center (TDC). The punch mark (A) on the variable valve timing control (VTC) actuator and the punch mark (B) on the exhaust camshaft sprocket should be at the top. Align the TDC marks (C) on the VTC actuator and the exhaust camshaft sprocket.

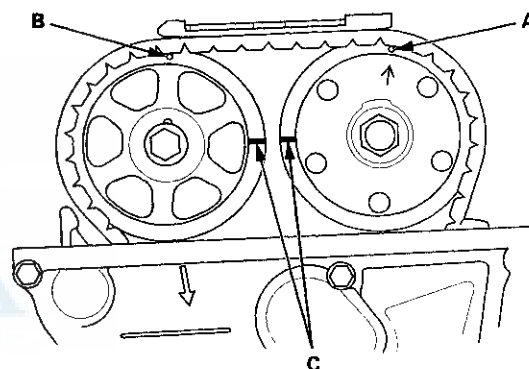

(cont'd)

Cylinder Head

Valve Clearance Adjustment (cont'd)

3. Select the correct feeler gauge for the valve clearance you are going to check.

Valve Clearance

Intake: 0.21–0.25 mm (0.008–0.010 in)

Exhaust: 0.25–0.29 mm (0.010–0.011 in)

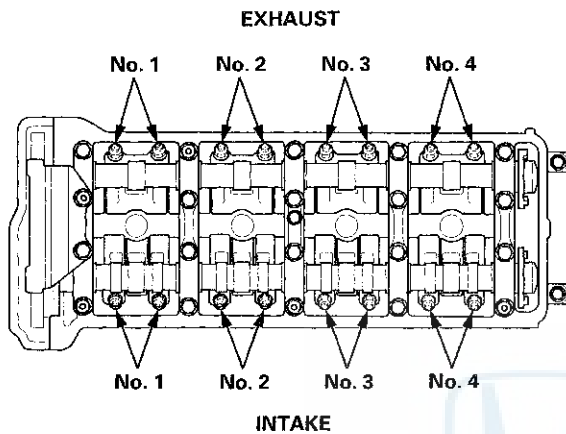

4. Insert the feeler gauge (A) between the adjusting screw (B) and the end of the valve stem, and slide it back and forth; you should feel a slight amount of drag.

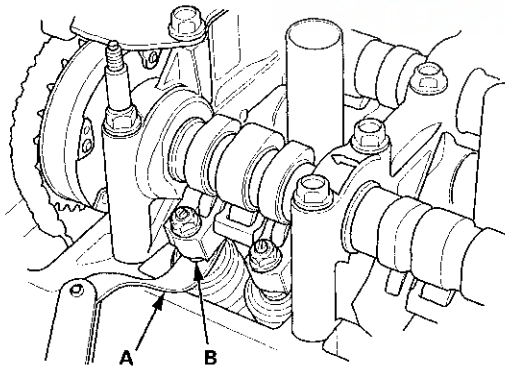

5. If you feel too much or too little drag, loosen the locknut with the locknut wrench and the adjuster, and turn the adjusting screw until the drag on the feeler gauge is correct.

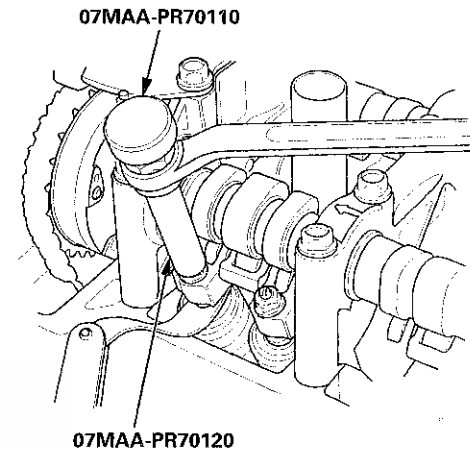

6. Tighten the locknut to the specified torque, and recheck the clearance. Repeat the adjustment if necessary.

Specified Torque

Intake:

7 x 0.75 mm

14 N·m (1.4 kgf·m, 10 lbf·ft)

Apply new engine oil to the nut threads.

Exhaust:

7 x 0.75 mm

14 N·m (1.4 kgf·m, 10 lbf·ft)

Apply new engine oil to the nut threads.



7. Rotate the crankshaft 180° clockwise (camshaft pulley turns 90°).

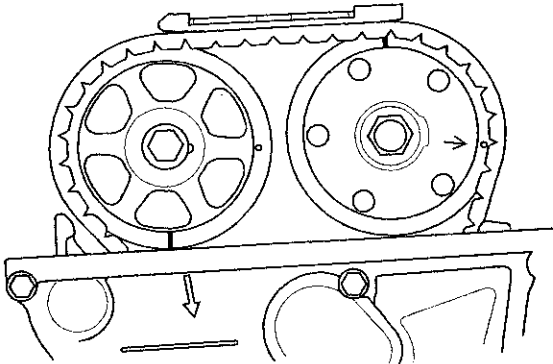

8. Check and, if necessary, adjust the valve clearance on the No. 3 cylinder.

9. Rotate the crankshaft 180° clockwise (camshaft pulley turns 90°).

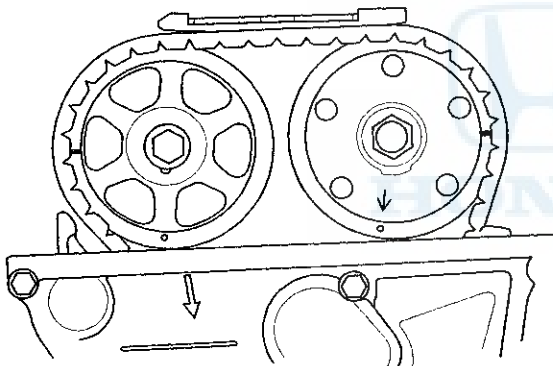

10. Check and, if necessary, adjust the valve clearance on the No. 4 cylinder.

11. Rotate the crankshaft 180° clockwise (camshaft pulley turns 90°).

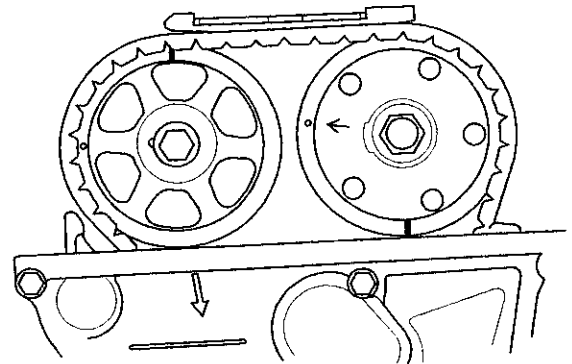

12. Check and, if necessary, adjust the valve clearance on the No. 2 cylinder.

13. Install the cylinder head cover (see page 6-25).

Cylinder Head

Crankshaft Pulley Removal and Installation

Special Tools Required

- Handle, 6-25-660L 07JAB-001020B
- Crankshaft Pulley Holder 07AAB-RJAA100
- Socket, 19 mm 07JAA-001020A or equivalent

Removal

1. Remove the front wheels.
2. Remove the splash shield (see step 25 on page 5-5).
3. Remove the drive belt (see page 4-30).
4. Hold the pulley with the handle, 6-25-660L (A) and the crankshaft pulley holder (B).

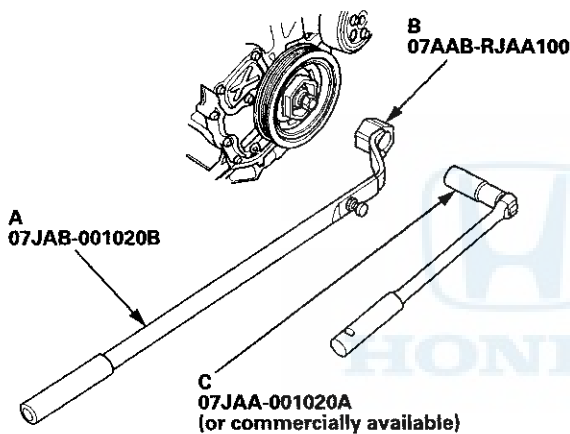

5. Remove the bolt with a socket, 19 mm (C) and a breaker bar, then remove the crankshaft pulley.

Installation

1. Clean the crankshaft pulley (A), the crankshaft (B), the bolt (C), and the washer (D). Lubricate with new engine oil as shown.

- : Clean
- : Lubricate

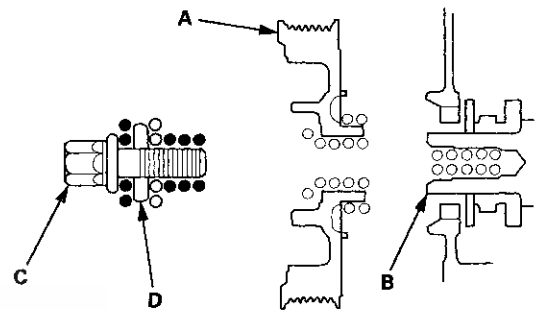

2. Install the crankshaft pulley, and hold the pulley with the handle (A) and the crankshaft pulley holder (B).

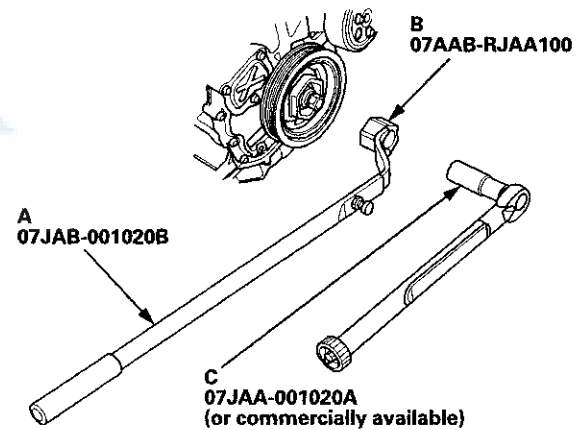

3. Torque the bolt to 49 N·m (5.0 kgf·m, 36 lbf·ft) with a torque wrench and socket, 19 mm (C). Do not use an impact wrench. If the pulley bolt or crankshaft are new, torque the bolt to 177 N·m (18.0 kgf·m, 130 lbf·ft), then remove the bolt and torque it to 49 N·m (5.0 kgf·m, 36 lbf·ft).
4. Tighten the pulley bolt an additional 90°.
5. Install the drive belt (see page 4-30).
6. Install the splash shield (see step 47 on page 5-20).
7. Install the front wheels.



Cam Chain Removal

NOTE: Keep the cam chain away from magnetic fields.

1. Remove the front wheels.
2. Remove the splash shield (see step 25 on page 5-5).
3. Remove the drive belt (see page 4-30).
4. Remove the cylinder head cover (see page 6-24).
5. Set the No. 1 piston at top dead center (TDC). The punch mark (A) on the variable valve timing control (VTC) actuator and the punch mark (B) on the exhaust camshaft sprocket should be at the top. Align the TDC marks (C) on the VTC actuator and the exhaust camshaft sprocket.

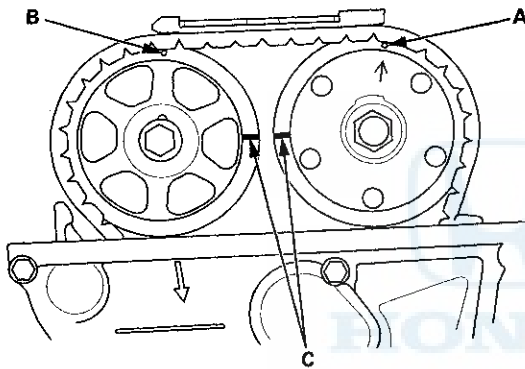

6. Disconnect the VTC oil control solenoid valve connector (A) and remove the harness clamp (B).

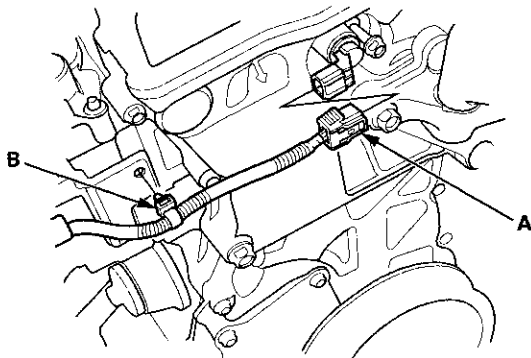

7. Remove the VTC oil control solenoid valve (see page 11-273).
8. Remove the crankshaft pulley (see page 6-12).
9. Support the engine with a jack and a wood block under the oil pan.
10. Remove the ground cable (A), then remove the side engine mount bracket (B).

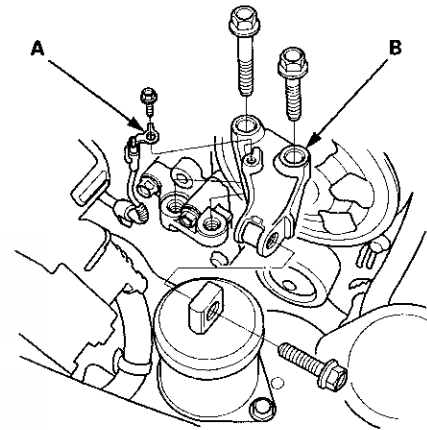

11. Remove the side engine mount bracket mounting bolts.

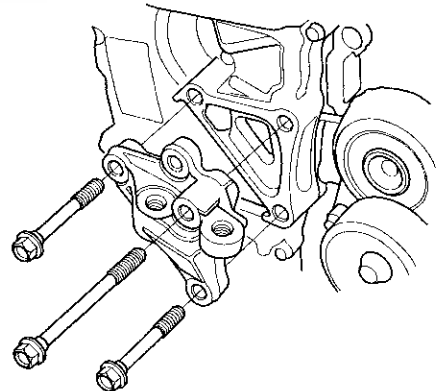

(cont'd)

Cylinder Head

Cam Chain Removal (cont'd)

12. Remove the cam chain case (A) and the spacer (B).

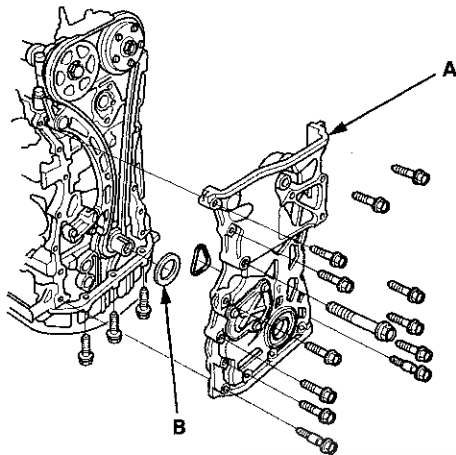

13. Loosely install the crankshaft pulley.

14. Turn the crankshaft counterclockwise to compress the auto-tensioner.

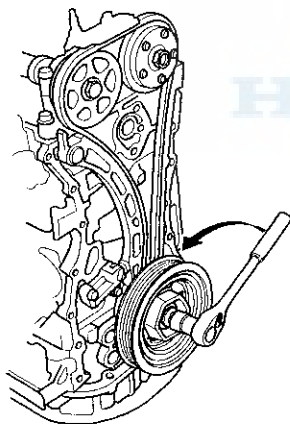

15. Align the holes on the lock (A) and the auto-tensioner (B), then insert a 1.2 mm (0.05 in) diameter pin or lock pin (P/N 14511-PNA-003) (C) into the holes. Turn the crankshaft clockwise to secure the pin.

NOTE: Check the auto-tensioner cam position. If the position are not aligned, set the first cam to the first edge of the rack.

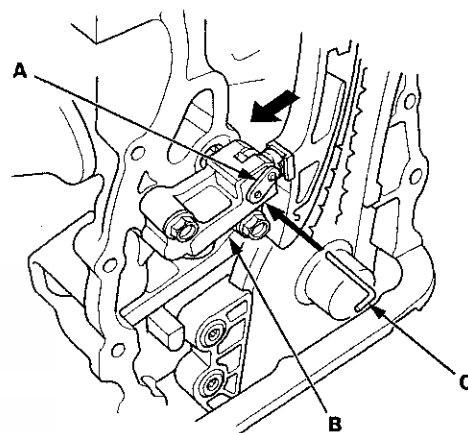

16. Remove the auto-tensioner.

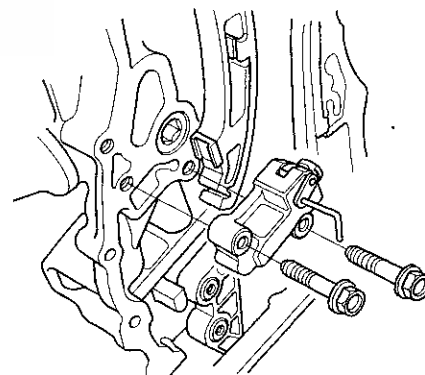



Cam Chain Installation

17. Remove cam chain guide B.

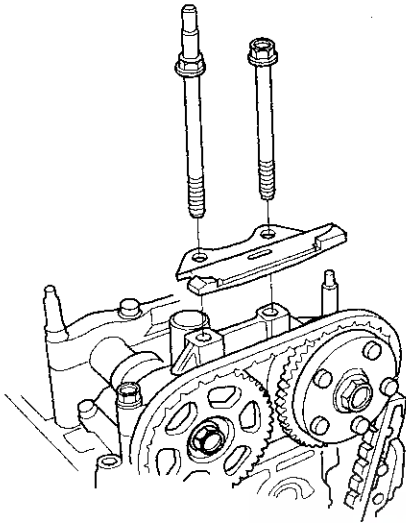

18. Remove cam chain guide A and the tensioner arm (B).

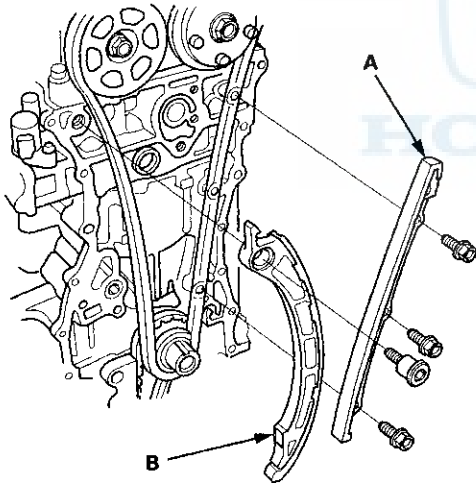

19. Remove the cam chain.

Special Tools Required

Camshaft Lock Pin Set 07AAB-RWCA120

- Keep the cam chain away from magnetic fields.
- Before doing this procedure, check that the variable valve timing control (VTC) actuator is locked by turning the VTC actuator counterclockwise. If not locked, turn the VTC actuator clockwise until it stops, then recheck it. If it is still not locked, replace the VTC actuator.

1. Set the crankshaft to top dead center (TDC). Align the TDC mark (A) on the crankshaft sprocket with the pointer (B) on the engine block.

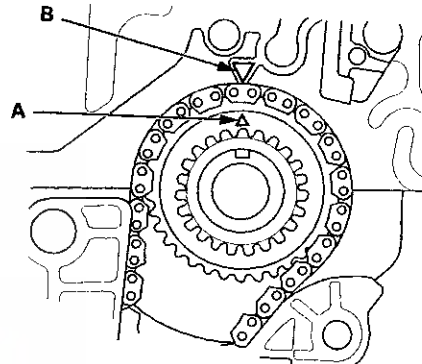

2. Set the camshafts to TDC. The punch mark (A) on the VTC actuator and the punch mark (B) on the exhaust camshaft sprocket should be at the top. Align the TDC marks (C) on the VTC actuator and the exhaust camshaft sprocket.

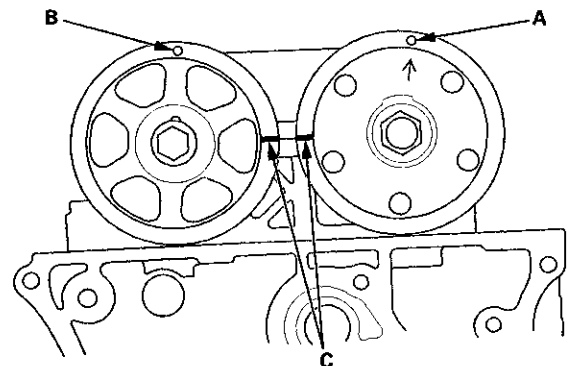

(cont'd)

Cylinder Head

Cam Chain Installation (cont'd)

3. To hold the intake camshaft, insert a camshaft lock pin set (07AAB-RWCA120) (A) into the maintenance hole in camshaft position (CMP) pulse plate A (B) and through the No. 5 rocker shaft holder (C).

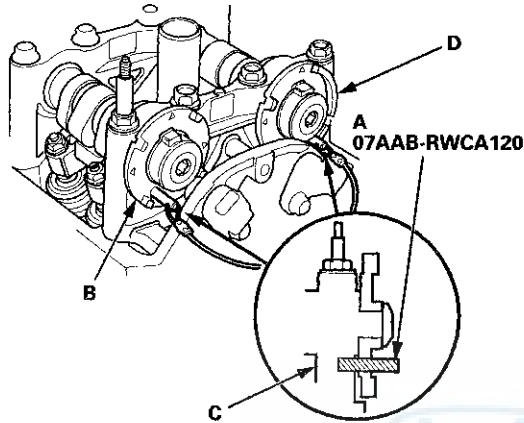

4. To hold the exhaust camshaft, insert a camshaft lock pin (A) into the maintenance hole in CMP pulse plate B (D) and through the No. 5 rocker shaft holder (C).

5. Install the cam chain on the crankshaft sprocket with the colored link plate (A) aligned with the mark (B) on the crankshaft sprocket.

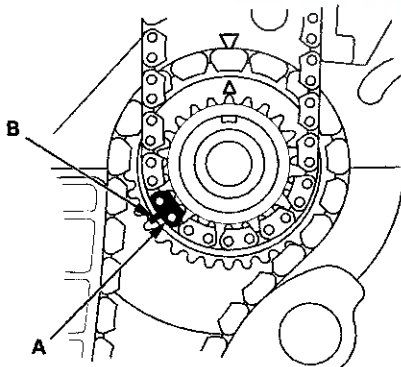

6. Install the cam chain on the VTC actuator and the exhaust camshaft sprocket with the punch marks (A) aligned with the center of the two colored link plates (B).

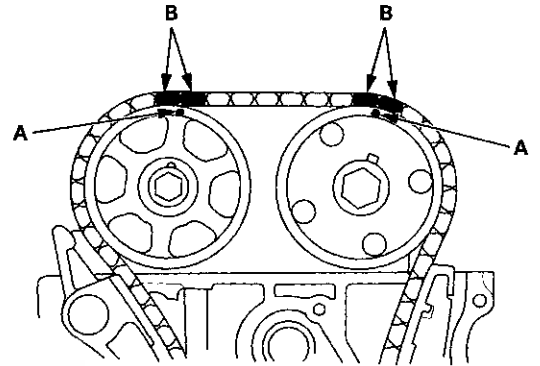

7. Install cam chain guide A and the tensioner arm (B).

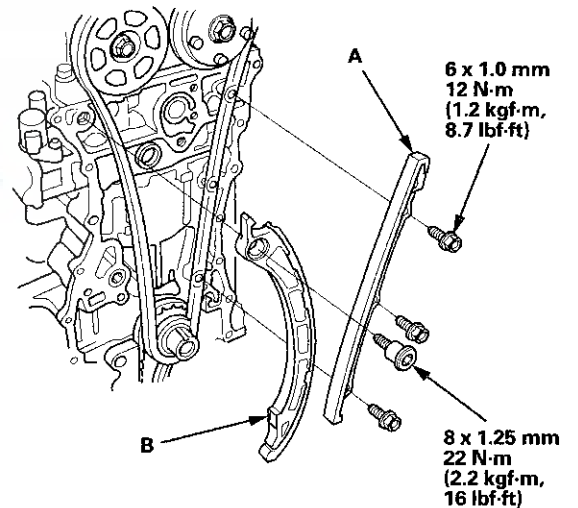



8. Install cam chain guide B.

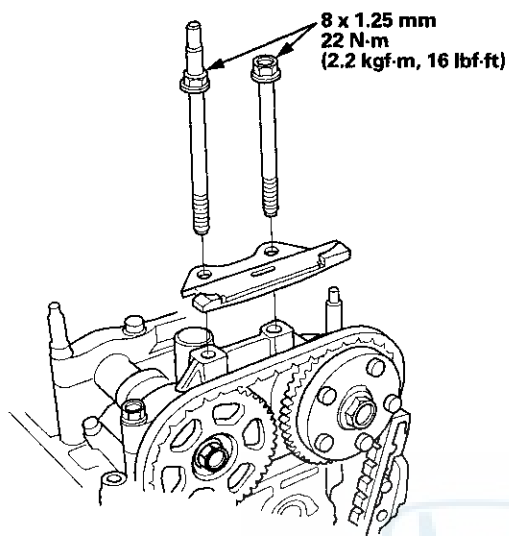

9. Compress the auto-tensioner when replacing the cam chain. Remove the pin (P/N 14511-PNA-003) (A) from the auto-tensioner that was installed during removal. Turn the plate (B) counterclockwise, to release the lock, then press the rod (C), and set the first cam (D) to the first edge of the rack (E). Insert the 1.2 mm (0.05 in) diameter pin or lock pin into the holes (F).

NOTE: If the chain tensioner is not set up as described, the tensioner will become damaged.

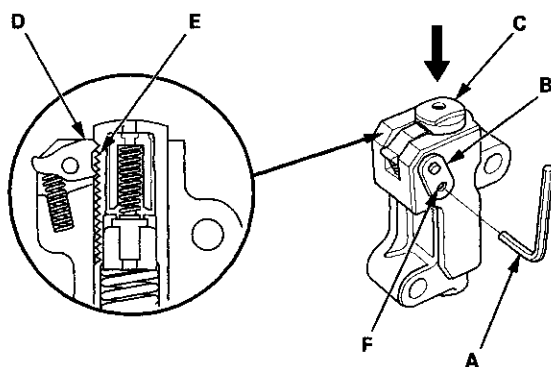

10. Install the auto-tensioner.

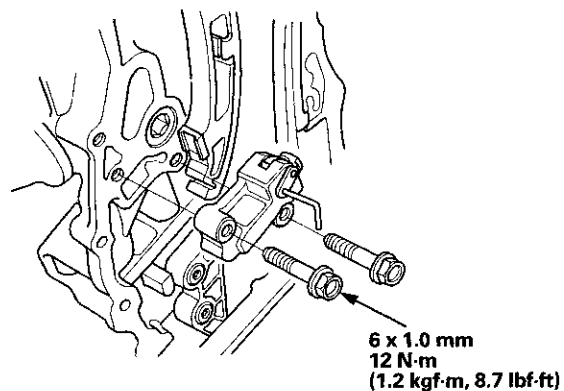

11. Remove the pin or lock pin from the auto-tensioner.

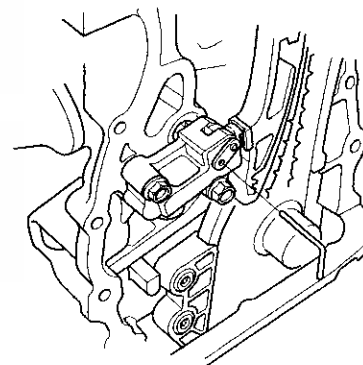

(cont'd)

Cylinder Head

Cam Chain Installation (cont'd)

12. Remove the camshaft lock pin set.

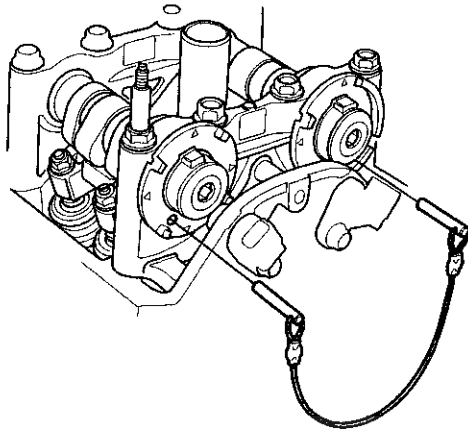

13. Check the chain case oil seal for damage. If the oil seal is damaged, replace the chain case oil seal (see page 6-22).

14. Remove the old liquid gasket from the chain case mating surfaces, the bolts, and the bolt holes.

15. Clean and dry the chain case mating surfaces.

16. Apply liquid gasket, P/N 08717-0004, 08718-0003, or 08718-0009, to the engine block mating surface of the chain case, and to the inside edge of the threaded bolt holes. Install the component within 5 minutes of applying the liquid gasket.

NOTE:

- Apply a 3 mm (0.12 in) diameter bead of liquid gasket along the broken line (A).
- If too much time has passed after applying the liquid gasket, remove the old liquid gasket and residue, then reapply new liquid gasket.

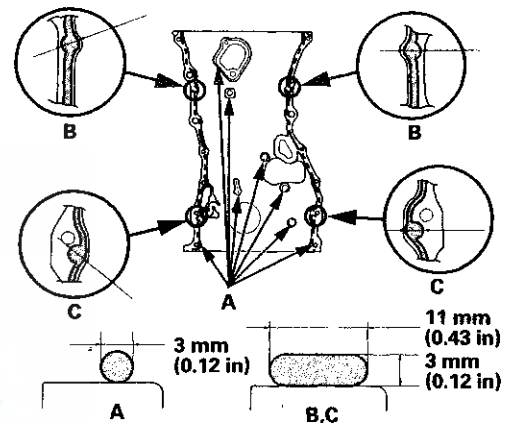

17. Apply liquid gasket to the engine block upper surface contact areas (B) on the chain case and lower block upper surface contact areas (C) on the chain case.

18. Apply liquid gasket, P/N 08717-0004, 08718-0003, or 08718-0009 to the oil pan mating surface of the chain case, and to the inside edge of the threaded bolt holes. Install the component within 5 minutes of applying the liquid gasket.

NOTE:

- Apply a 3 mm (0.12 in) diameter bead of liquid gasket along the broken line (A).
- If too much time has passed after applying the liquid gasket, remove the old liquid gasket and residue, then reapply new liquid gasket.

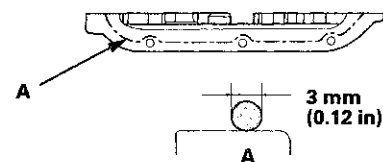



19. Install the spacer (A), then install the new O-ring (B) on the chain case. Set the edge of the chain case (C) to the edge of the oil pan (D), then install the chain case on the engine block (E). Wipe off the excess liquid gasket on the oil pan and chain case mating surface.

NOTE:

- When installing the chain case, do not slide the bottom surface onto the oil pan mounting surface.
- Wait at least 30 minutes before filling the engine with oil.
- Do not run the engine for at least 3 hours after installing the chain case.

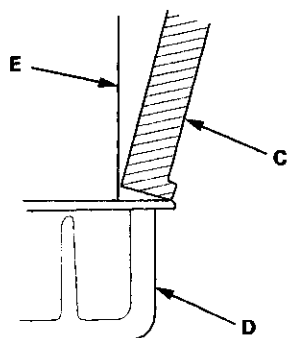
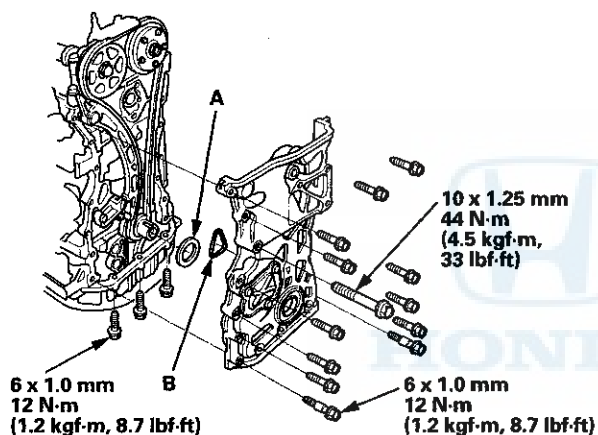

20. Install the side engine mount bracket, then tighten the side engine mount bracket mounting bolts.

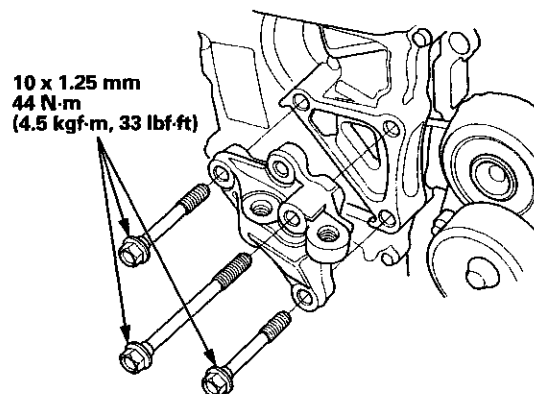

21. Tighten the new side engine mount bracket mounting bolts in the numbered sequence shown.

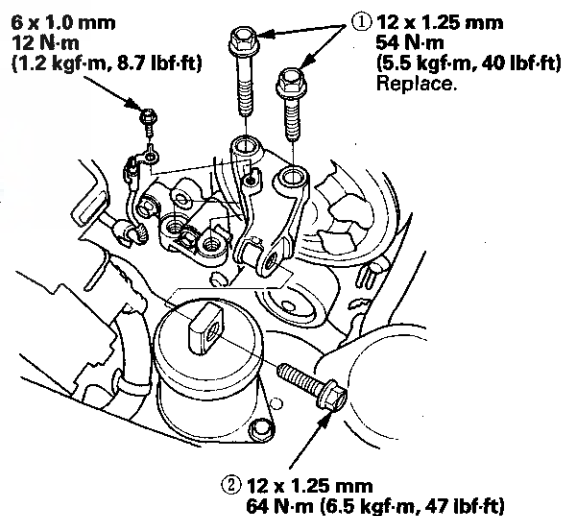

22. Install the ground cable.

23. Remove the jack and the wood block.

(cont'd)

Cylinder Head

Cam Chain Installation (cont'd)

24. Install the crankshaft pulley (see page 6-12).
25. Install the VTC oil control solenoid valve (see page 11-273).
26. Connect the VTC oil control solenoid valve connector (A) and install the harness clamp (B).

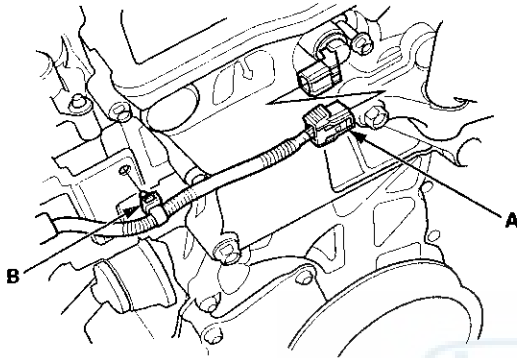

27. Install the cylinder head cover (see page 6-25).
28. Install the drive belt (see page 4-30).
29. Install the splash shield (see step 47 on page 5-20).
30. Install the front wheels.
31. Do the crankshaft position (CKP) pattern clear/CKP pattern learn procedure (see page 11-5).

Cam Chain Auto-tensioner Removal and Installation

Removal

1. Remove the chain case cover.

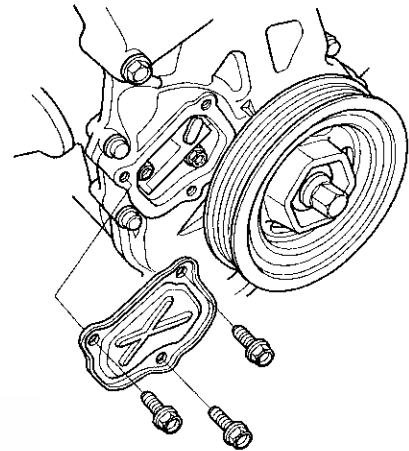

2. Turn the crankshaft counterclockwise to compress the auto-tensioner.

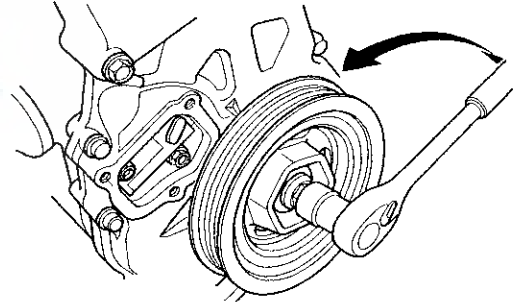



3. Align the holes on the lock (A) and the auto-tensioner (B), then insert a 1.2 mm (0.05 in) diameter pin or lock pin (P/N 14511-PNA-003) (C) into the holes. Turn the crankshaft clockwise to secure the pin.

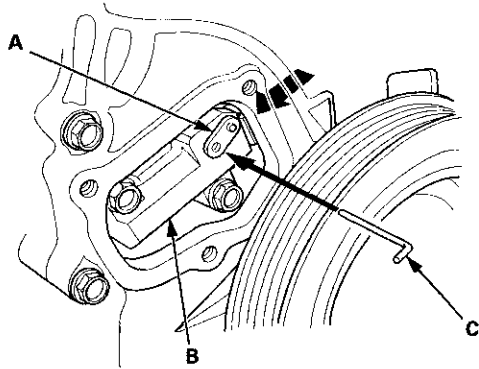

4. Remove the auto-tensioner.

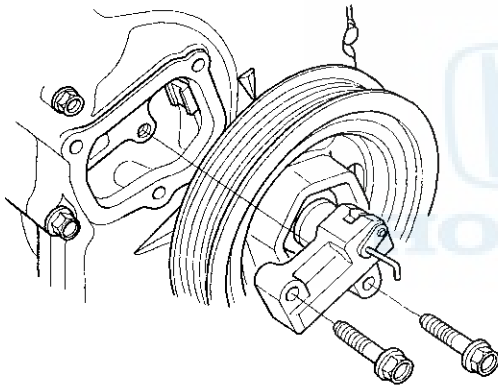

Installation

1. Install the auto-tensioner.

NOTE: Check the auto-tensioner cam position. If the position is not aligned, set the first cam to the first edge of the rack (see step 9 on page 6-17).

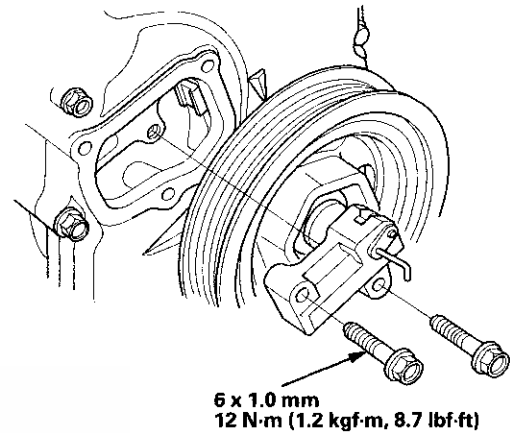

2. Remove the 1.2 mm (0.05 in) diameter pin or lock pin (P/N 14511-PNA-003) from the auto-tensioner.

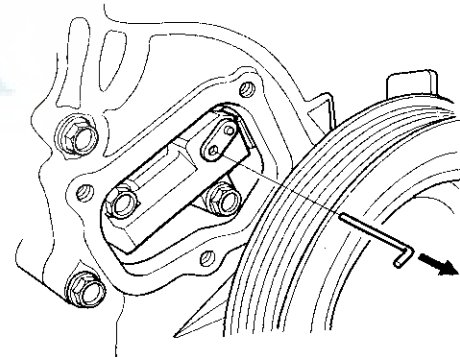

3. Remove all of the old liquid gasket from the chain case cover mating surfaces, the bolts, and the bolt holes.
4. Clean and dry the chain case cover mating surfaces.

(cont'd)

Cylinder Head

Cam Chain Auto-tensioner Removal and Installation (cont'd)

5. Apply liquid gasket, P/N 08717-0004, 08718-0003, or 08718-0009 to the chain case mating surface of the chain case cover, and to the inside edge of the threaded bolt holes. Install the component within 5 minutes of applying the liquid gasket.

NOTE:

- Apply a 3 mm (0.12 in) diameter bead of liquid gasket along the broken line (A).
- If too much time has passed after applying the liquid gasket, remove the old liquid gasket and residue, then reapply new liquid gasket.

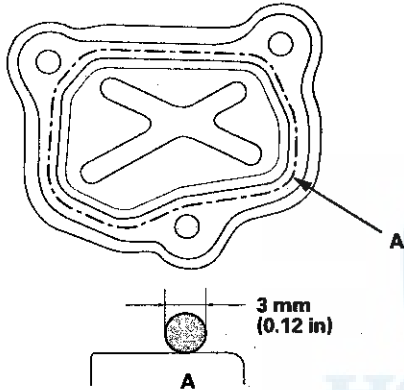

6. Install the chain case cover.

NOTE:

- Wait at least 30 minutes before filling the engine with oil.
- Do not run the engine for at least 3 hours after installing the chain case cover.

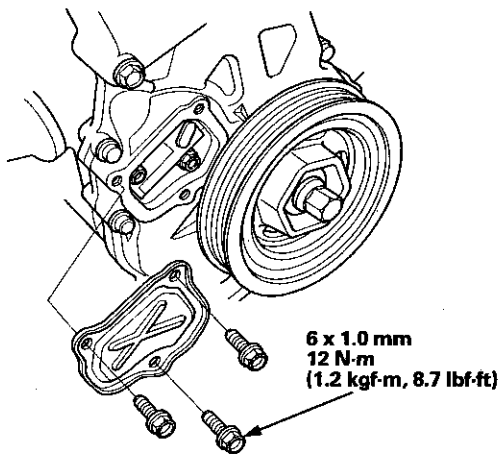

Cam Chain Case Oil Seal Installation

Special Tools Required

- Driver Handle, 15 x 135L 07749-0010000
- Attachment, 52 x 55 mm 07746-0010400

1. Clean and dry the crankshaft oil seal.
2. Apply a light coat of new engine oil to the lip of the chain case oil seal.
3. Use the driver handle, 15 x 135L and the attachment, 52 x 55 mm to drive a new oil seal squarely into the chain case to the specified installed height.

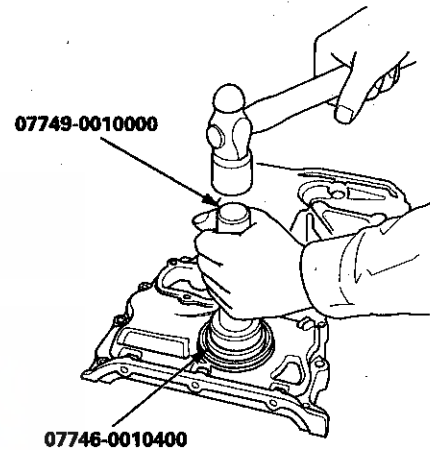

4. Measure the distance between the chain case surface (A) and the oil seal (B).

Oil Seal Installed Height:
32.4–33.1 mm (1.28–1.30 in)

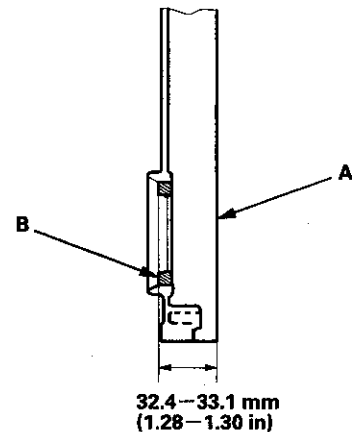



Cam Chain Inspection

Special Tools Required

Cam Chain Inspection Gauge 07AAJ-RWCA100

1. Remove the front wheels.
2. Remove the splash shield (see step 25 on page 5-5).
3. Remove the cylinder head cover (see page 6-24).
4. Rotate the crankshaft pulley two turns clockwise.
5. Set the No. 1 piston at top dead center (TDC). The punch mark (A) on the variable valve timing control (VTC) actuator and the punch mark (B) on the exhaust camshaft sprocket should be at the top. Align the TDC marks (C) on the VTC actuator and the exhaust camshaft sprocket.

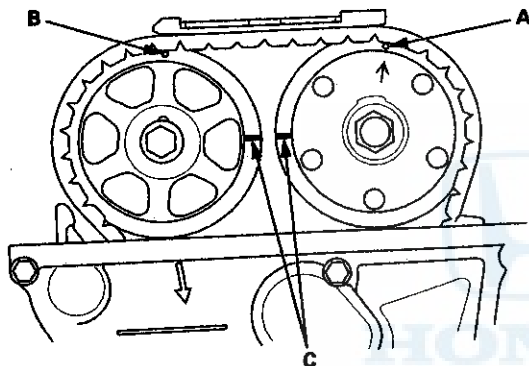

6. Measure the clearance between the cam chain (A) and the tensioner arm (B) with the cam chain inspection gauge (07AAJ-RWCA100).

- If the clearance is OK, go to step 17.
- If the clearance is more than the service limit, go to step 7.

Chain-to-Arm Clearance

Service Limit:

MIL on with P0341: 4.3 mm (0.17 in)

Without MIL: 5.5 mm (0.22 in)

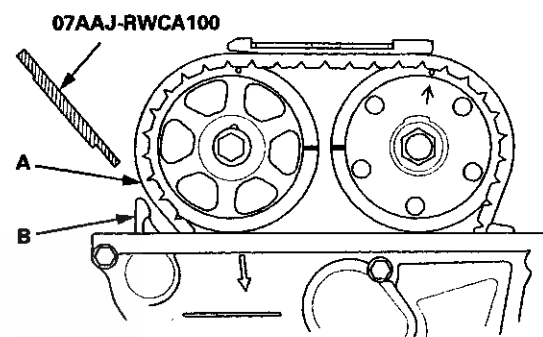

7. Remove the oil pan (see page 7-11).

8. Support the engine with a jack and a wood block under the engine block.

NOTE: Do not hit the oil pump and the baffle plate when placing the jack on the edge of the engine block.

9. Remove the cam chain (see page 6-13), and check the teeth on the crankshaft sprocket, the VTC actuator, and the exhaust camshaft sprocket for wear and damage. If any of them are worn or damaged, replace if necessary.
10. Check the oil passage on the auto-tensioner for clogs. If the auto-tensioner is clogged, replace it.

(cont'd)

Cylinder Head

Cam Chain Inspection (cont'd)

11. Measure the length of the oil pump chain auto-tensioner rod.

**Oil Pump Chain Auto-Tensioner Rod Length
Service Limit: 13 mm (0.51 in)**

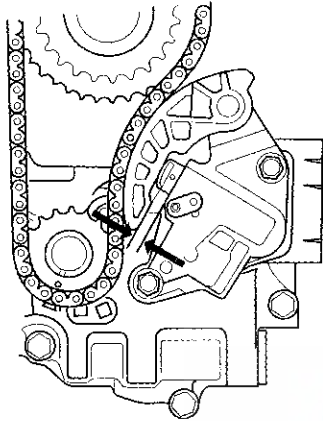

12. If the length is over the service limit, replace the oil pump chain (see page 8-25). When replacing, check the teeth on the crankshaft sprocket and the oil pump sprocket for wear and damage. If any of them are worn or damaged, replace if necessary.
13. Check the oil passage on the oil pump chain auto-tensioner for clogs. If the auto-tensioner is clogged, replace it.
14. Install the new cam chain (see page 6-15).
15. Remove the jack and the wood block.
16. Install the oil pan (see page 7-30).
17. Install the cylinder head cover (see page 6-25).
18. Install the splash shield (see step 47 on page 5-20).
19. Install the front wheels.

Cylinder Head Cover Removal

1. Remove the strut brace (if equipped) (see page 20-306).
2. Remove the engine cover.

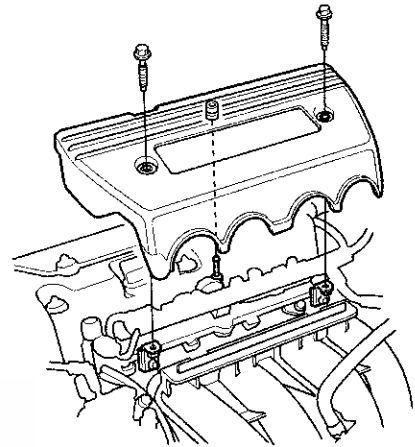

3. Remove the four ignition coils (see page 4-20).
4. Remove the dipstick (A) and the power steering (P/S) hose bracket (B) and disconnect the breather hose (C) and the brake booster vacuum hose (D).

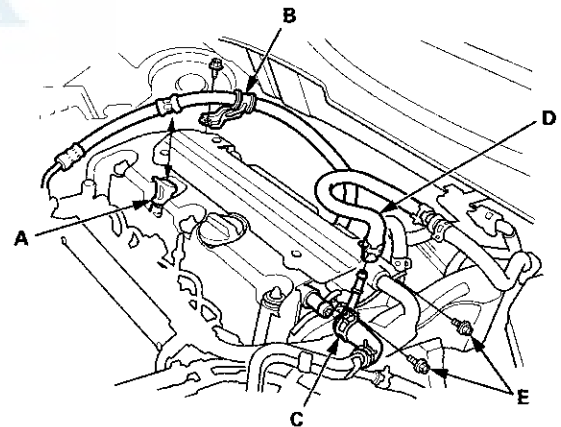

5. Remove the two bolts (E) securing the evaporative emission (EVAP) canister purge valve bracket.



Cylinder Head Cover Installation

6. Remove the cylinder head cover.

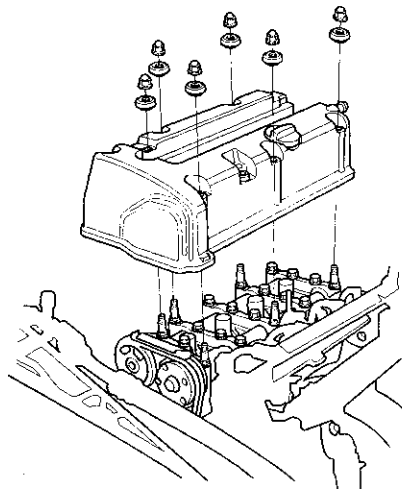

1. Thoroughly clean the head cover gasket and the groove.
2. Install the head cover gasket (A) in the groove of the cylinder head cover (B).

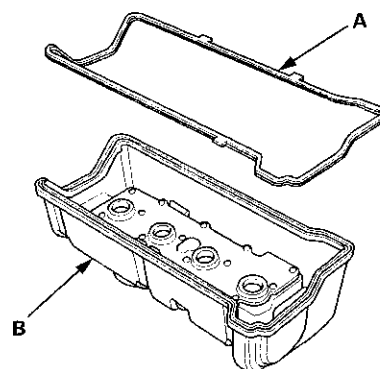

3. Check that the mating surfaces are clean and dry.
4. Apply liquid gasket, P/N 08717-0004, 08718-0003, or 08718-0009, on the chain case and the No. 5 rocker shaft holder mating areas (A). Install the component within 5 minutes of applying the liquid gasket.

NOTE: If too much time has passed after applying the liquid gasket, remove the old liquid gasket and residue, then reapply new liquid gasket.

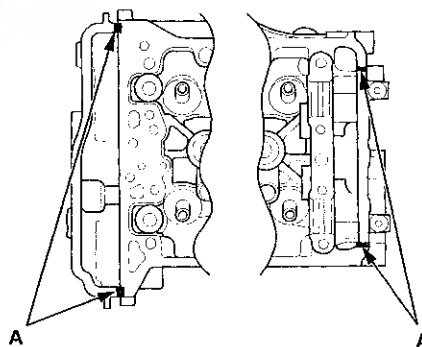

(cont'd)

Cylinder Head

Cylinder Head Cover Installation (cont'd)

5. Set the spark plug seals (A) on the spark plug tubes. Place the cylinder head cover (B) on the cylinder head, then slide the cover slightly back and forth to seat the head cover gasket.

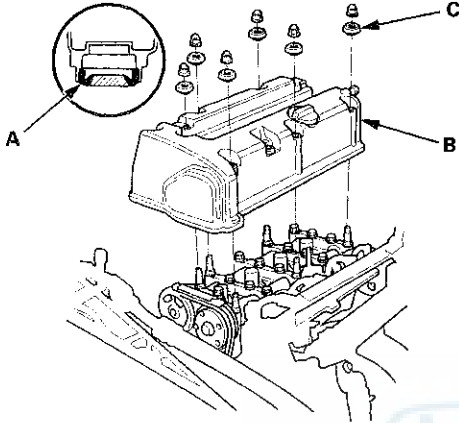

6. Inspect the cover washers (C). Replace any washer that is damaged or deteriorated.
7. Torque the bolts in three steps. In the final step tighten all bolts, in sequence, to 12 N·m (1.2 kgf·m, 8.7 lbf·ft).

NOTE:

- Wait at least 30 minutes before filling the engine with oil.
- Do not run the engine for at least 3 hours after installing the head cover.

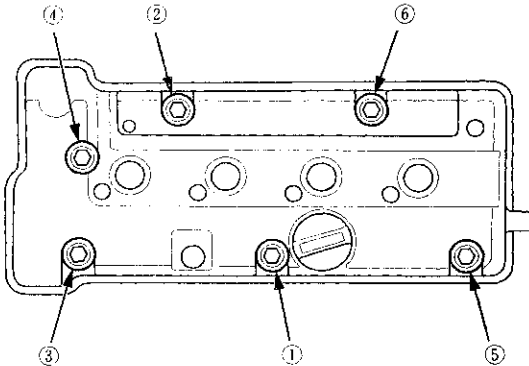

8. Install the two bolts (A) securing the evaporative emission (EVAP) canister purge valve bracket.

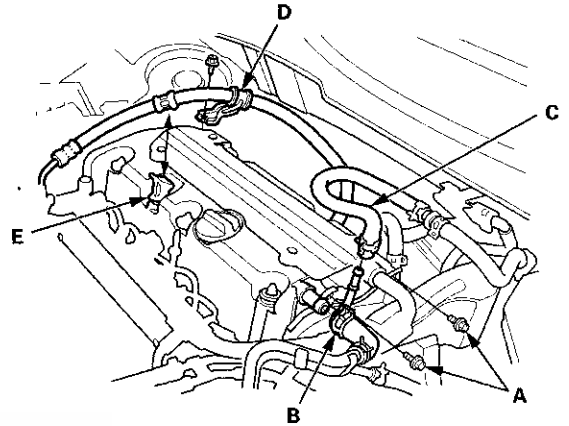

9. Connect the breathe hose (B) and the brake booster vacuum hose (C) and install the power steering (P/S) hose bracket (D), and the dipstick (E).
10. Install the four ignition coils (see page 4-20).
11. Install the engine cover.

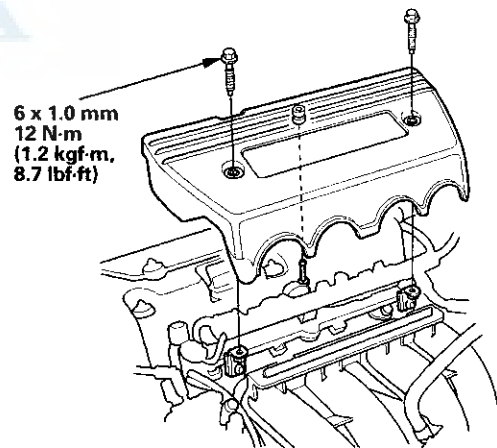

12. Install the strut brace (if equipped) (see page 20-306).



Cylinder Head Removal

NOTE:

- Use fender covers to avoid damaging painted surfaces.
- To avoid damage, unplug the wiring connectors carefully while holding the connector portion.
- Connect the Honda Diagnostic System (HDS) to the data link connector (DLC), and monitor the engine coolant temperature (ECT) sensor 1. To avoid damaging the cylinder head, wait until the ECT sensor 1 temperature drops below 100 °F (38 °C) before loosening the cylinder head bolts.
- Mark all wiring and hoses to avoid misconnection. Also, be sure that they do not contact other wiring or hoses, or interfere with any other parts.

1. Remove the strut brace (if equipped) (see page 20-306).
2. Relieve the fuel pressure (see page 11-306).
3. Drain the engine coolant (see page 10-6).
4. Remove the drive belt (see page 4-30).
5. Remove the intake manifold (see page 9-4).
6. Remove the catalytic converter (see page 11-339).
7. Disconnect the evaporative emission (EVAP) canister hose (A).

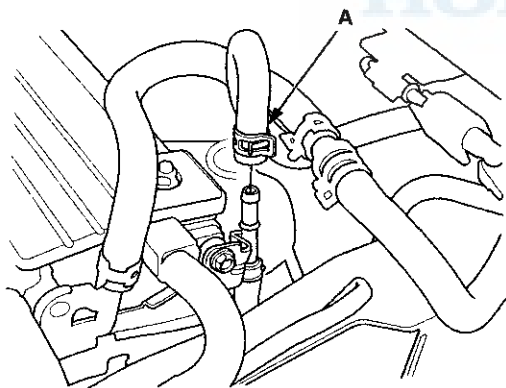

8. Remove the quick-connect fitting cover (A), then disconnect the fuel feed hose (B) (see page 11-314).

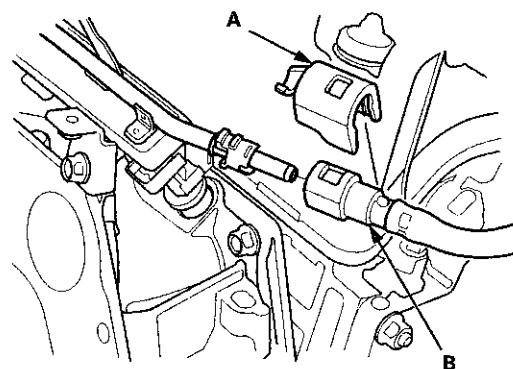

9. Disconnect the four fuel injector connectors (A), the engine mount control solenoid valve connector (B), and remove the ground cables (C).

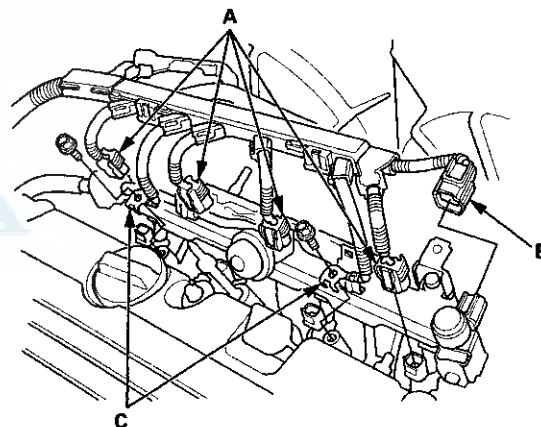

(cont'd)

Cylinder Head

Cylinder Head Removal (cont'd)

10. Remove the four bolts securing the EVAP canister purge valve bracket.

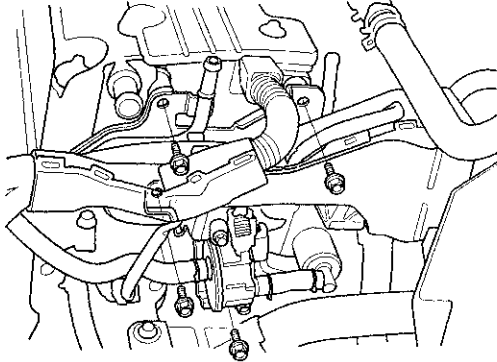

11. Disconnect the upper radiator hose (A), the heater hoses (B), and the water bypass hose (C).

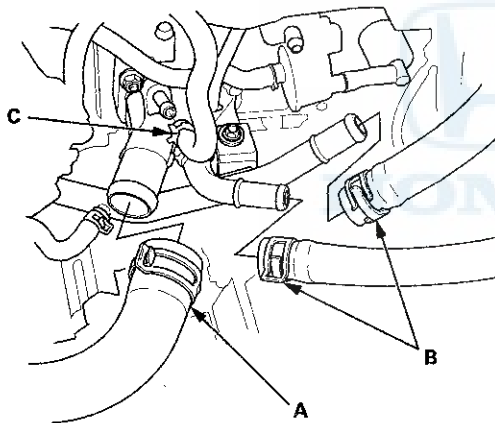

12. Remove the two bolts (A) securing the connecting pipe.

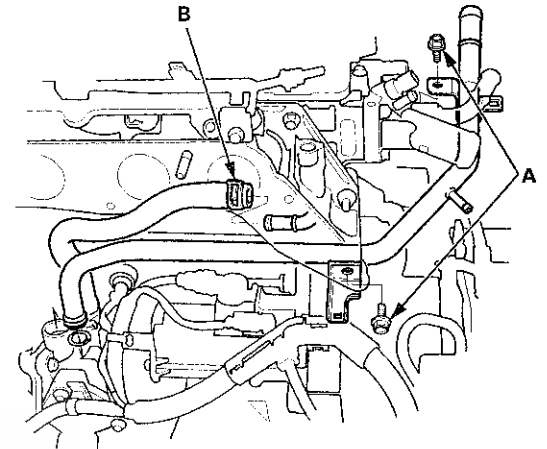

13. Disconnect the water bypass hose (B).

14. Disconnect the following engine wire harness connectors, and remove the wire harness clamps from the cylinder head:

- Engine coolant temperature (ECT) sensor 1 connector
- Camshaft position (CMP) sensor A (Intake) connector
- Camshaft position (CMP) sensor B (Exhaust) connector
- Rocker arm oil control valve connector
- Rocker arm oil pressure switch connector
- EVAP canister purge valve connector
- Variable valve timing control (VTC) oil control solenoid valve connector
- Engine oil pressure switch connector



CMP Pulse Plate A Replacement

15. Remove the cam chain (see page 6-13).
16. Remove the rocker arm assembly (see page 6-32).
17. Remove the cylinder head bolts. To prevent warpage, loosen the bolts in sequence 1/3 turn at a time; repeat the sequence until all bolts are loosened.

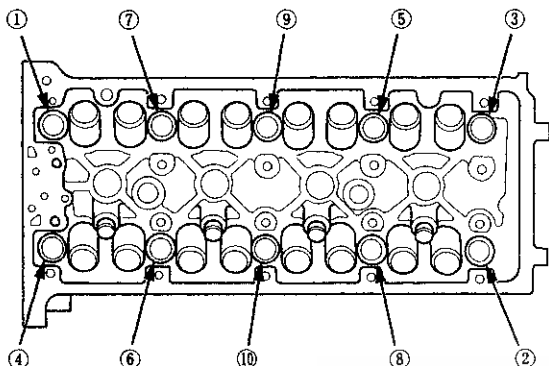

18. Remove the cylinder head.

1. Remove the cylinder head cover (see page 6-24).
2. Remove camshaft position (CMP) sensor A (see page 11-274).
3. Hold the camshaft with an open-end wrench, then loosen the bolt.

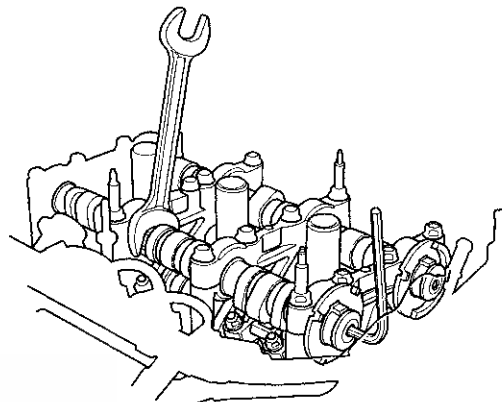

4. Remove CMP pulse plate A.

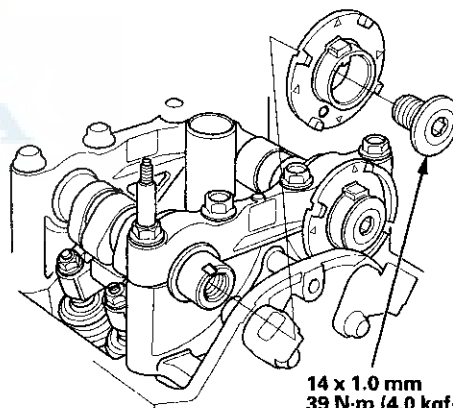

14 x 1.0 mm
39 N·m (4.0 kgf·m, 29 lbf·ft)
Apply new engine oil to
the bolt threads.

5. Install CMP pulse plate A in the reverse order of removal.

Cylinder Head

CMP Pulse Plate B Replacement

1. Remove the cylinder head cover (see page 6-24).
2. Remove camshaft position (CMP) sensor B (see page 11-198).
3. Hold the camshaft with an open-end wrench, then loosen the bolt.

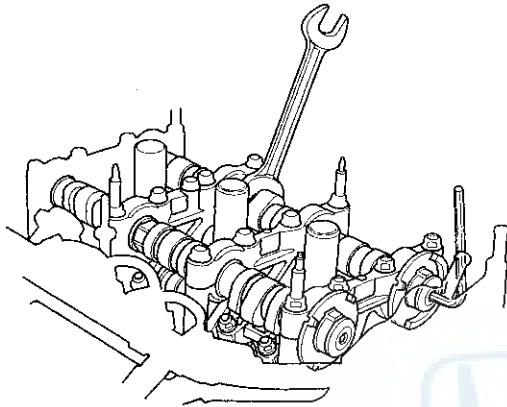

4. Remove CMP pulse plate B.

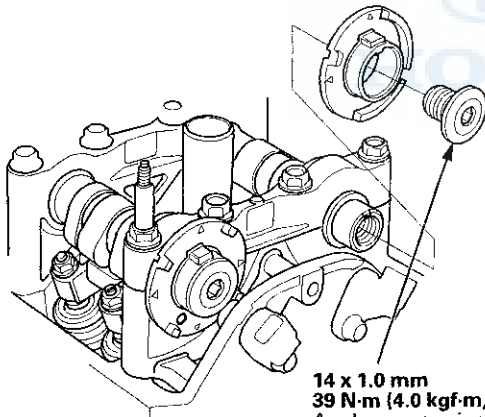

14 x 1.0 mm
39 N·m (4.0 kgf·m, 29 lbf·ft)
Apply new engine oil to
the bolt threads.

5. Install CMP pulse plate B in the reverse order of removal.

VTC Actuator, Exhaust Camshaft Sprocket Replacement

Removal

1. Remove the cam chain (see page 6-13).
2. Hold the camshaft with an open-end wrench, then loosen the variable valve timing control (VTC) actuator mounting bolt and the exhaust camshaft sprocket mounting bolt.

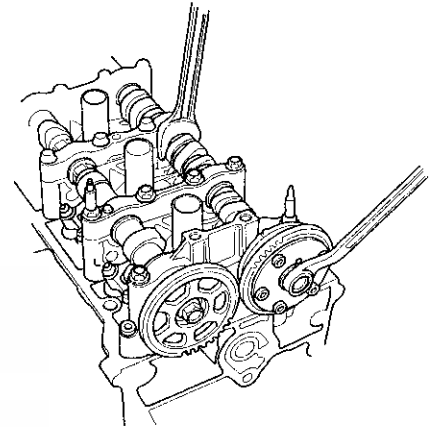

3. If the VTC actuator will be reused, do these steps.
 - 1. Remove the intake camshaft, and seal the retard holes in the No. 1 camshaft journal with tape and a wire tie (see step 6 on page 6-8).
 - 2. Seal one of the advance holes with tape (see step 7 on page 6-8).
 - 3. Apply air to the unsealed advance hole to release the lock (see step 8 on page 6-9).
 - 4. Remove the tape and adhesive residue from the camshaft journal.
4. Remove the VTC actuator and the exhaust camshaft sprocket.



Installation

1. Install the VTC actuator and the exhaust camshaft sprocket.

NOTE: Install the VTC actuator while in the unlocked position.

2. Apply new engine oil to the threads of the VTC actuator mounting bolt and the exhaust camshaft mounting bolt, then install them.
3. Hold the camshaft with an open-end wrench, then tighten the bolts.

Specified Torque

VTC Actuator Mounting Bolt:

12 x 1.25 mm

113 N·m (11.5 kgf·m, 83 lbf·ft)

Exhaust Camshaft Sprocket Mounting Bolt:

10 x 1.25 mm

72 N·m (7.3 kgf·m, 53 lbf·ft)

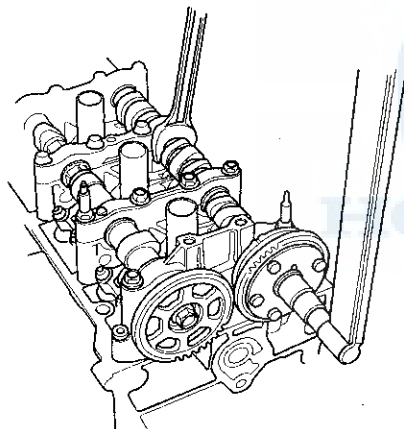

4. Hold the camshaft, and turn the VTC actuator clockwise until you hear it click. Make sure to lock the VTC actuator by turning it.
5. Install the cam chain (see page 6-15).

Cylinder Head Inspection for Warpage

1. Remove the cylinder head (see page 6-27).
2. Inspect the camshaft (see page 6-35).
3. Check the cylinder head for warpage. Measure along the edges, and three ways across the center.
 - If warpage is less than 0.05 mm (0.002 in) cylinder head resurfacing is not required.
 - If warpage is between 0.05 mm (0.002 in) and 0.2 mm (0.008 in), resurface the cylinder head.
 - The maximum resurface limit is 0.2 mm (0.008 in) based on a height of 104 mm (4.09 in).

Cylinder Head Height

Standard (New): 103.95–104.05 mm
(4.093–4.096 in)

Service Limit: 103.8 mm (4.087 in)

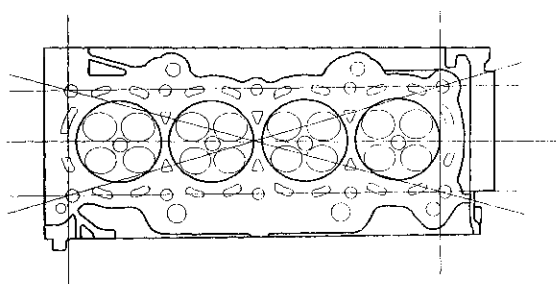
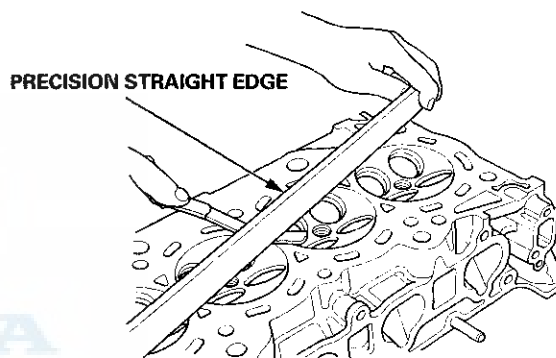

Cylinder Head

Rocker Arm Assembly Removal

1. Remove the cam chain (see page 6-13).
2. Loosen the rocker arm adjusting screws (A).

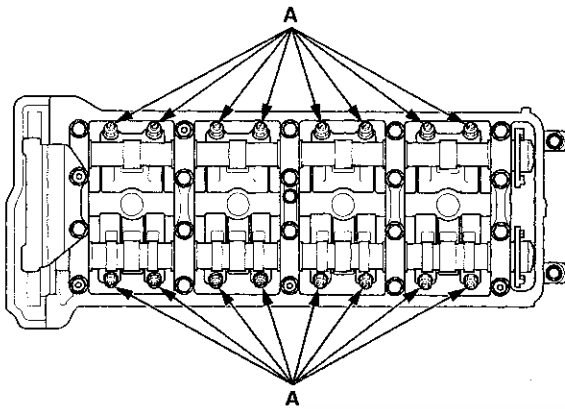

3. Remove the camshaft holder bolts. To prevent damaging the camshafts, loosen the bolts, in sequence, two turns at a time.

NOTE: Bolt ① is not on all engines.

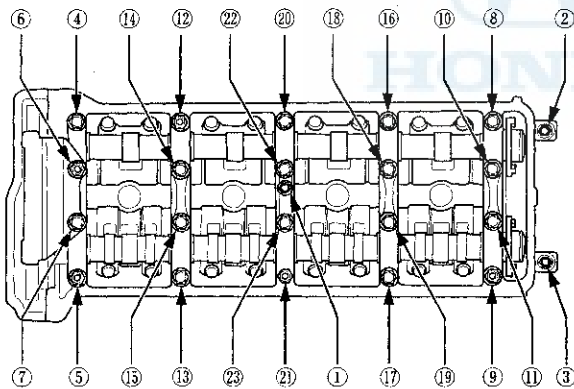

4. Remove cam chain guide B (A), the camshaft holders (B), and the camshafts (C).

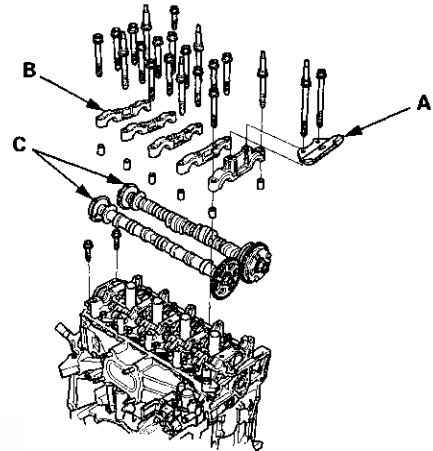

5. Insert the bolts (A) into the rocker shaft holder, then remove the rocker arm assembly (B).

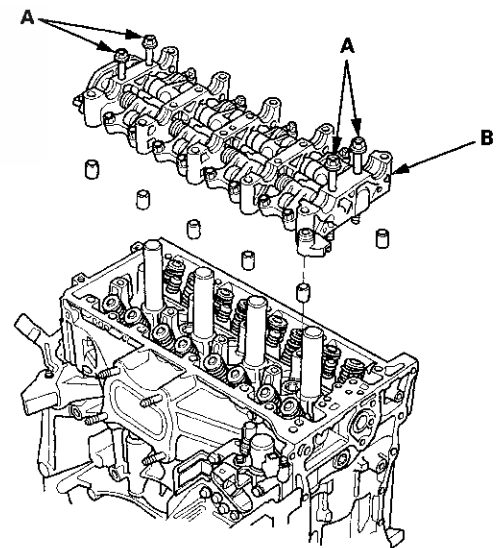



Rocker Arm and Shaft Disassembly/Reassembly

NOTE:

- Identify each part as it is removed so that each item can be reinstalled in its original locations.
- Inspect the rocker arm shaft and rocker arms (see page 6-34).
- If reused, the rocker arms must be installed in the original locations.
- When removing, or installing the rocker arm assembly, do not remove the camshaft holder bolts. The bolts will keep the holders and rocker arms on the shaft.
- Prior to reassembling, clean all the parts in solvent, dry them, and apply new engine oil to any contact points.
- Bundle the intake rocker arms with rubber bands to keep them together as a set.
- When replacing the intake rocker arm assembly, remove the fastening hardware from the new intake rocker arm assembly.

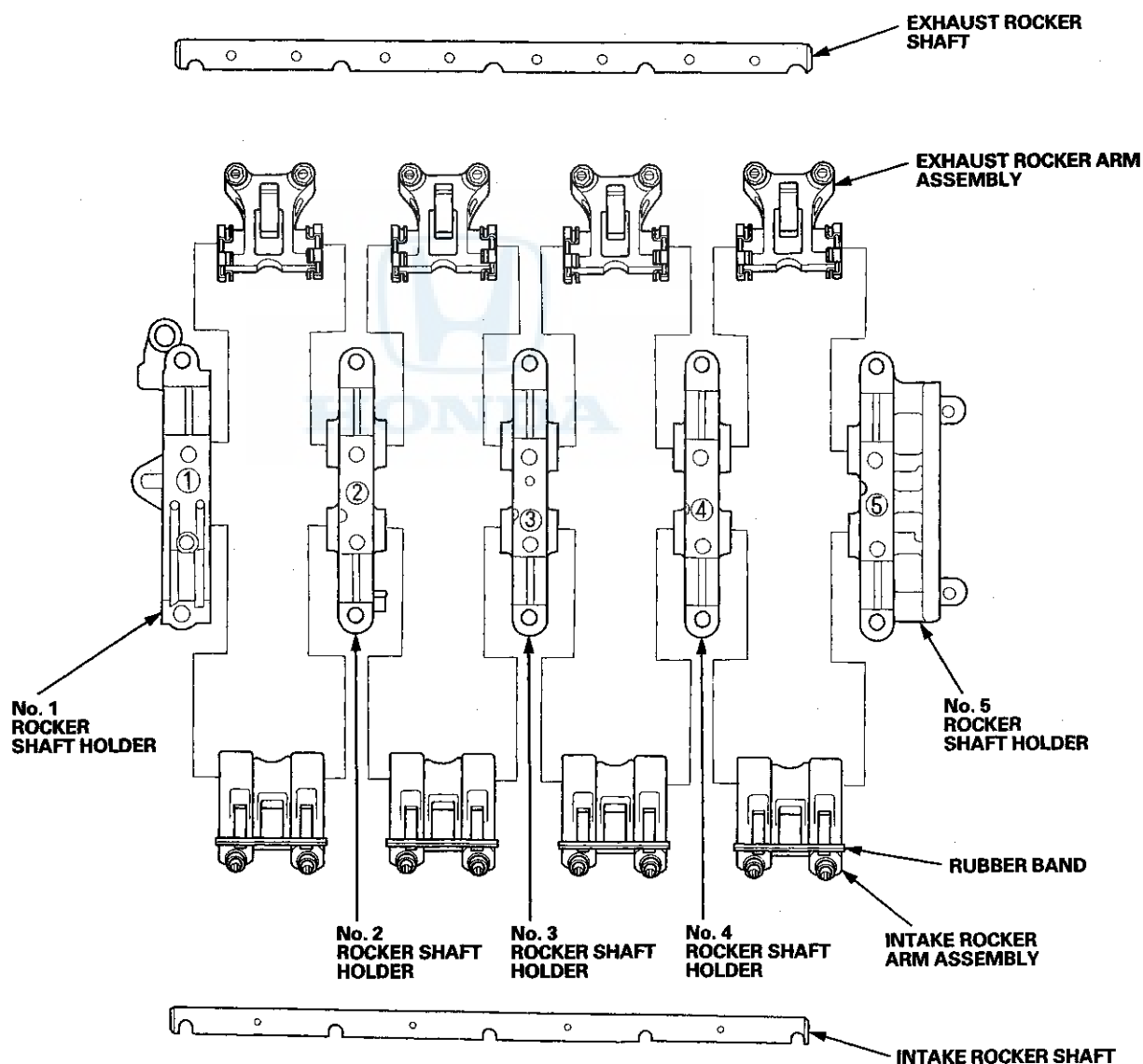

Cylinder Head

Rocker Arm and Shaft Inspection

1. Remove the rocker arm assembly (see page 6-32).
2. Disassemble the rocker arm assembly (see page 6-33).
3. Measure the diameter of the shaft at the first rocker location.

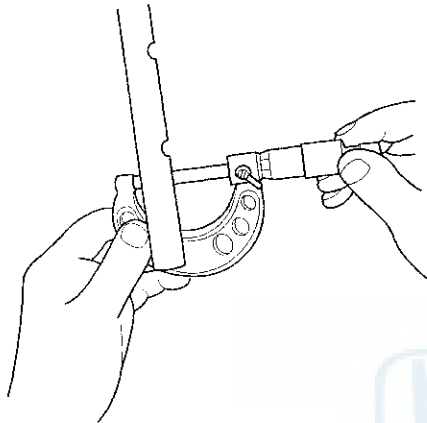

4. Zero the gauge (A) to the shaft diameter.

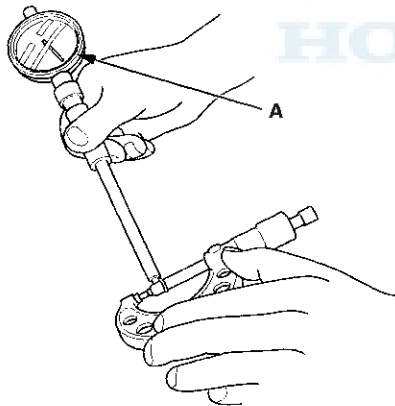

5. Measure the inside diameter of the rocker arm, and check it for an out-of-round condition.

Rocker Arm-to-Shaft Clearance

Standard (New):

Intake: 0.018–0.059 mm
(0.0007–0.0023 in)

Exhaust: 0.018–0.056 mm
(0.0007–0.0022 in)

Service Limit: 0.08 mm (0.003 in)

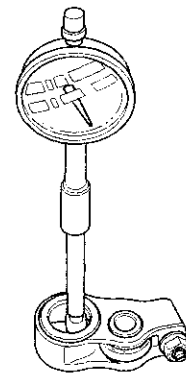

6. Repeat for all rocker arms and both shafts. If the clearance is beyond the service limit, replace the rocker shaft and all out of service limit rocker arms. If any VTEC rocker arm needs replacement, replace the rocker arms (primary, mid, and secondary), as a set.

7. Inspect the rocker arm pistons (A). Push on each piston manually. If it does not move smoothly, replace the rocker arm set.

NOTE: Apply new engine oil to the rocker arm pistons when reassembling.

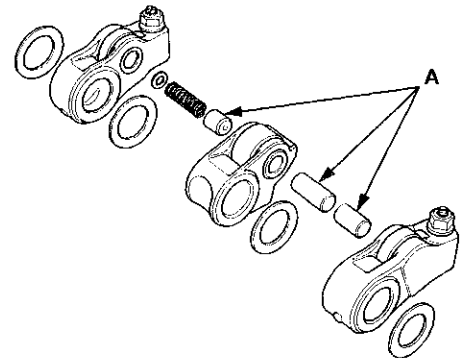

8. Reassemble the rocker arm assembly (see page 6-33).

9. Install the rocker arm assembly (see page 6-43).



Camshaft Inspection

NOTE: Do not rotate the camshaft during inspection.

1. Remove the cylinder head (see page 6-27).
2. Disassemble the rocker arm assembly (see page 6-33).
3. Remove the rocker arm assembly (see page 6-32).
4. Put the rocker shaft holders, the camshaft, and the camshaft holders on the cylinder head, then tighten the bolts, in sequence, to the specified torque.

NOTE: If the engine does not have bolt ⑳, skip it and continue the torque sequence.

Specified Torque

8 x 1.25 mm 22 N·m (2.2 kgf·m, 16 lbf·ft)

6 x 1.0 mm 12 N·m (1.2 kgf·m, 8.7 lbf·ft)

6 x 1.0 mm Bolts: ⑳, ㉑, ㉒

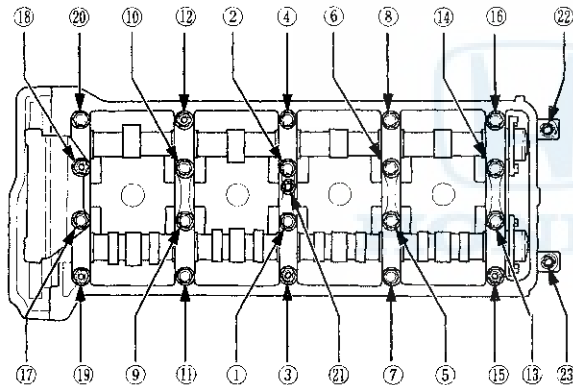

5. Seat the camshaft by pushing it away from the camshaft pulley end of the cylinder head.
6. Zero the dial indicator against the end of the camshaft, then push the camshaft back and forth, and read the end play. If the end play is beyond the service limit, replace the cylinder head and recheck. If it is still beyond the service limit, replace the camshaft.

Camshaft End Play

Standard (New): 0.05–0.20 mm (0.002–0.008 in)

Service Limit: 0.4 mm (0.02 in)

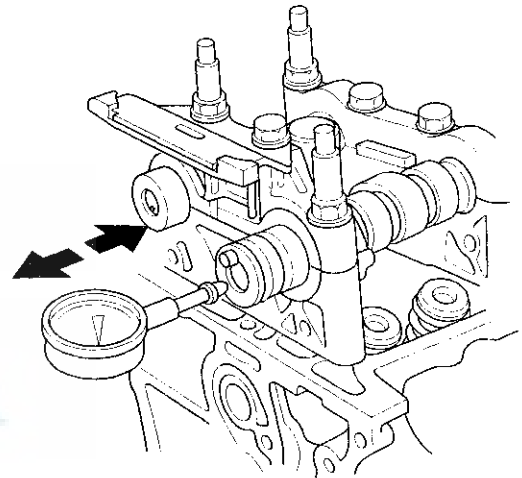

(cont'd)

Cylinder Head

Camshaft Inspection (cont'd)

7. Loosen the camshaft holder bolts two turns at a time, in a crisscross pattern. Then remove the camshaft holders from the cylinder head.
8. Lift the camshafts out of the cylinder head, and wipe them clean, then inspect the lift ramps. Replace the camshaft if any lobes are pitted, scored, or excessively worn.
9. Clean the camshaft journal surfaces in the cylinder head, then set the camshafts back in place. Place a plastigage strip across each journal.
10. Install the camshaft holders, then tighten the bolts to the specified torque as shown in step 4.
11. Remove the camshaft holders. Measure the widest portion of plastigage on each journal.
 - If the camshaft-to-holder clearance is within the service limits, go to step 13.
 - If the camshaft-to-holder clearance is beyond the service limit, and the camshaft has been replaced, replace the cylinder head.
 - If the camshaft-to-holder clearance is beyond the service limit, and the camshaft has not been replaced, go to step 12.

Camshaft-to-Holder Oil Clearance

Standard (New):

No. 1 Journal: 0.030–0.069 mm
(0.0012–0.0027 in)

No. 2, 3, 4, 5 Journals: 0.060–0.099 mm
(0.0024–0.0039 in)

Service Limit: 0.15 mm (0.006 in)

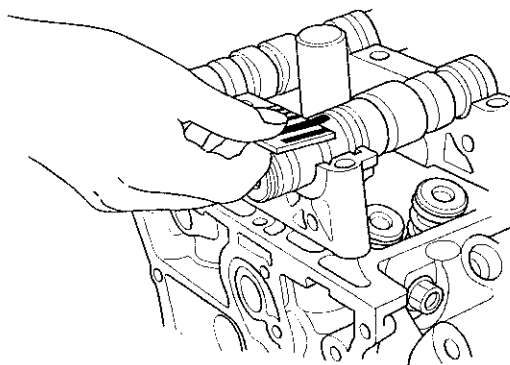

12. Check the total runout with the camshaft supported on V-blocks.
 - If the total runout of the camshaft is within the service limit, replace the cylinder head.
 - If the total runout is beyond the service limit, replace the camshaft and recheck the camshaft-to-holder oil clearance. If the oil clearance is still beyond the service limit, replace the cylinder head.

Camshaft Total Runout

Standard (New): 0.03 mm (0.001 in) max.

Service Limit: 0.04 mm (0.002 in)

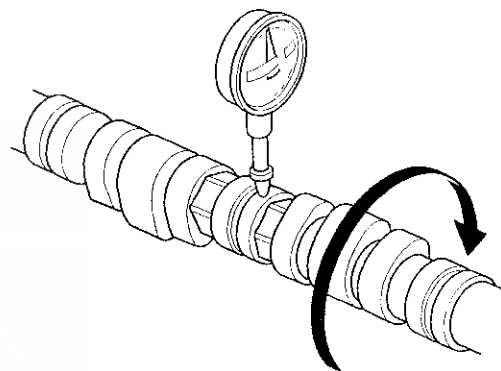

13. Measure the cam lobe height.

Cam Lobe Height Standard (New):

	INTAKE	EXHAUST
PRI	33.744 mm (1.3285 in)	34.291 mm (1.3500 in)
MID	35.456 mm (1.3959 in)	
SEC	33.744 mm (1.3285 in)	

PRI: Primary MID: Mid SEC: Secondary

C/C: Cam Chain

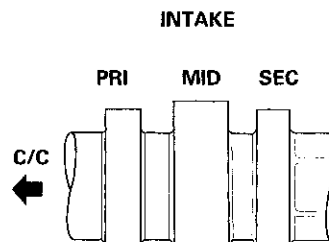



Valve, Spring, and Valve Seal Removal

Special Tools Required

Valve Spring Compressor Attachment 07757-PJ1010A

Identify the valves and the valve springs as they are removed so that each item can be reinstalled in its original position.

1. Remove the cylinder head (see page 6-27).
2. Remove the rocker arm assembly (see page 6-32).
3. Using an appropriate-sized socket (A) and a plastic mallet (B), lightly tap the spring retainer to loosen the valve cotters.

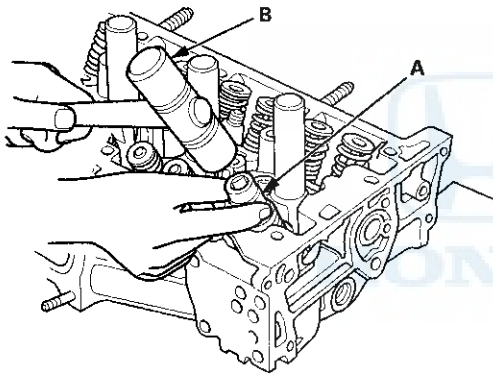

4. Install the valve spring compressor attachment and the valve spring compressor. Compress the spring, and remove the valve cotters.

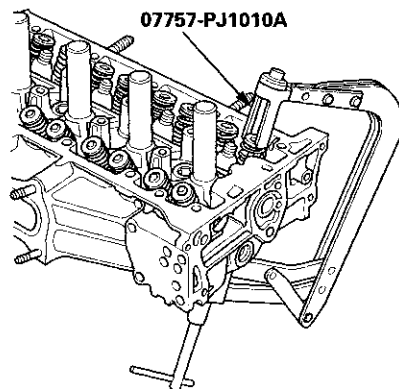

5. Remove the valve spring compressor and the valve spring compressor attachment, then remove the spring retainer, the valve spring, and the valves.

6. Install the valve guide seal remover.

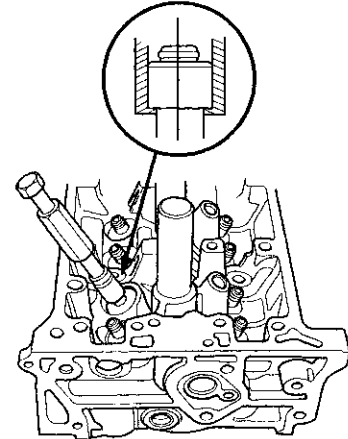

7. Remove the valve seal.

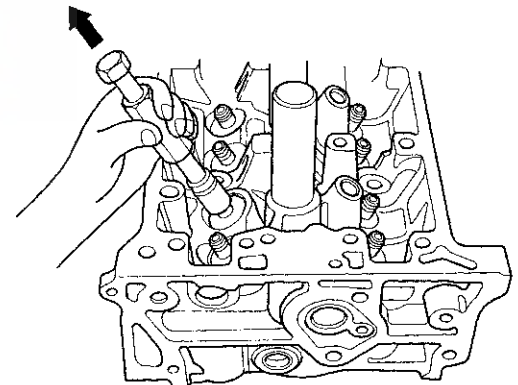

Cylinder Head

Valve Inspection

1. Remove the valves (see page 6-37).
2. Measure the valve in these areas.

Intake Valve Dimensions

A Standard (New): 35.85–36.15 mm
(1.411–1.423 in)

B Standard (New): 108.5–109.1 mm
(4.272–4.295 in)

C Standard (New): 5.475–5.485 mm
(0.2156–0.2159 in)

C Service Limit: 5.445 mm (0.2144 in)

Exhaust Valve Dimensions

A Standard (New): 30.85–31.15 mm
(1.215–1.226 in)

B Standard (New): 108.4–109.0 mm
(4.268–4.291 in)

C Standard (New): 5.450–5.460 mm
(0.2146–0.2150 in)

C Service Limit: 5.42 mm (0.213 in)

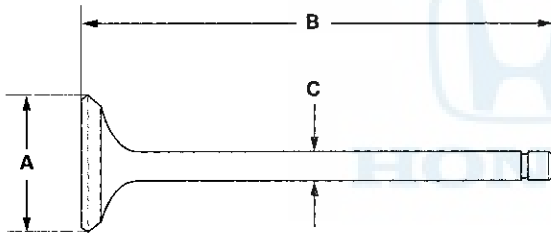

Valve Stem-to-Guide Clearance Inspection

1. Remove the valves (see page 6-37).
2. Subtract the O.D. of the valve stem, measured with a micrometer, from the I.D. of the valve guide, measured with an inside micrometer or a ball gauge. Take the measurements in three places along the valve stem and three places inside the valve guide. The difference between the largest guide measurement and the smallest stem measurement should not exceed the service limit.

Intake Valve Stem-to-Guide Clearance

Standard (New): 0.030–0.055 mm
(0.0012–0.0022 in)

Service Limit: 0.08 mm (0.003 in)

Exhaust Valve Stem-to-Guide Clearance

Standard (New): 0.055–0.080 mm
(0.0022–0.0031 in)

Service Limit: 0.11 mm (0.004 in)

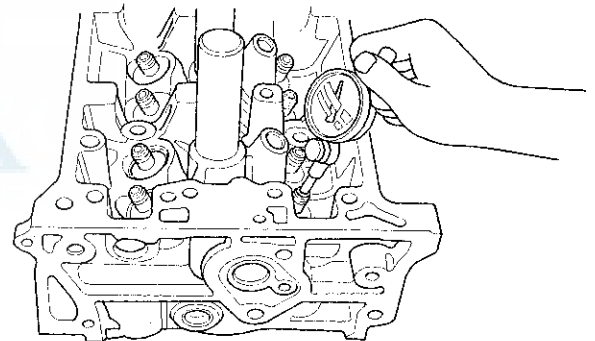



Valve Guide Replacement

Special Tools Required

- Valve Guide Driver, 5.35 x 9.7 mm 07742-0010100
- Valve Guide Reamer, 5.5 mm 07HAH-PJ7A100

1. Inspect the valve stem-to-guide clearance (see page 6-38).
2. As illustrated, use a commercially available air-impact valve guide driver (A) modified to fit the diameter of the valve guides. In most cases, the same procedure can be done using the valve guide driver, 5.35 x 9.7 mm and a conventional hammer.

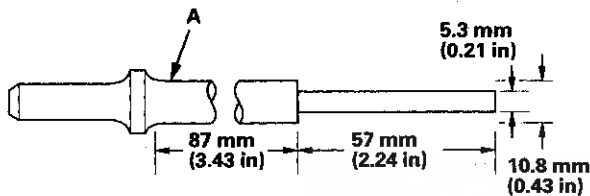

3. Select the proper replacement guides, and chill them in the freezer section of a refrigerator for at least an hour.
4. Use a hot plate or oven to evenly heat the cylinder head to 300 °F (150 °C). Monitor the temperature with a cooking thermometer. Do not get the head hotter than 300 °F (150 °C); excessive heat may loosen the valve seats.

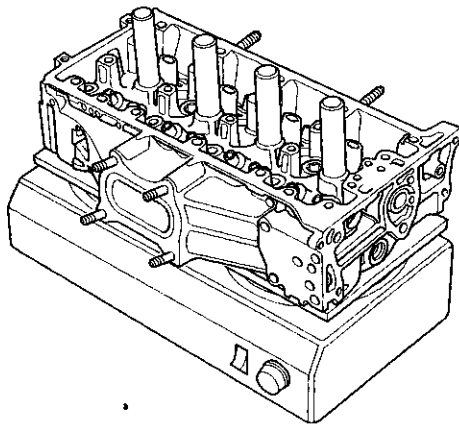

5. Working from the camshaft side, use the driver and an air hammer to drive the guide about 2 mm (0.1 in) towards the combustion chamber. This will knock off some of the carbon and make removal easier. Hold the air hammer directly in line with the valve guide to prevent damaging the driver.
6. Turn the head over, and drive the guide out toward the camshaft side of the head.

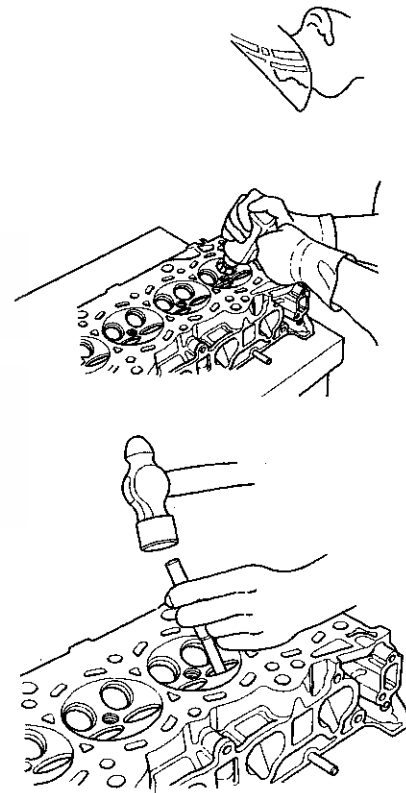

7. If a valve guide will not move, drill it out with an 8 mm (5/16 in) bit, then try again.

NOTE: Drill guides only in extreme cases; you could damage the cylinder head if the guide breaks.

8. Remove the new guide(s) from the freezer, one at a time, as you need them.

(cont'd)

Cylinder Head

Valve Guide Replacement (cont'd)

9. Apply a thin coat of new engine oil to the outside of the new valve guide. Install the guide from the camshaft side of the head; use the valve guide driver to drive the guide in to the specified installed height (A) of the guide (B). If you have all 16 guides to do, you may have to reheat the head.

Valve Guide Installed Height

Intake: 15.2–16.2 mm (0.60–0.64 in)

Exhaust: 15.5–16.5 mm (0.61–0.65 in)

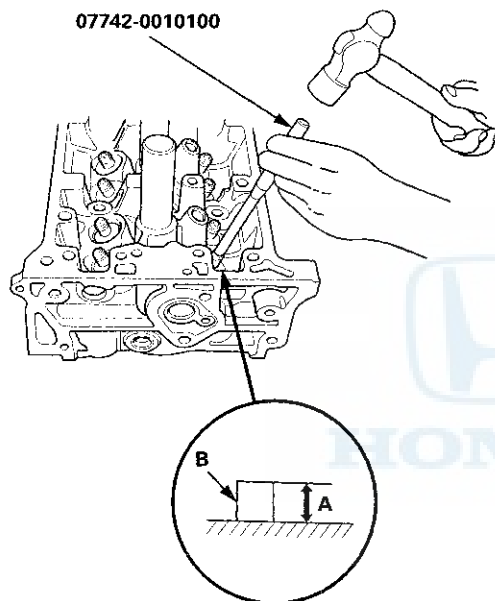

10. Coat both the valve guide reamer, 5.5 mm and the valve guide with cutting oil.

11. Rotate the valve guide reamer clockwise to the full length of the valve guide bore.

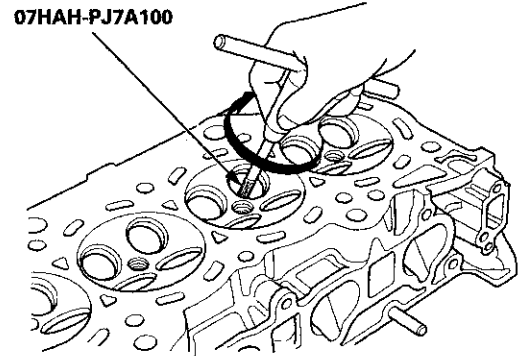

12. Continue to rotate the reamer clockwise while removing it from the bore.

13. Thoroughly wash the guide in detergent and water to remove any cutting residue.

14. Check the clearances with a valve (see page 6-38). Verify that a valve slides into the intake and exhaust valve guides without sticking.

15. Inspect the valve seating, if necessary renew the valve seat using a valve seat cutter (see page 6-41).



Valve Seat Reconditioning

1. Inspect the valve stem-to-guide clearance (see page 6-38). If the valve guides are worn, replace them (see page 6-39) before cutting the valve seats.
2. Renew the valve seats in the cylinder head using a valve seat cutter.

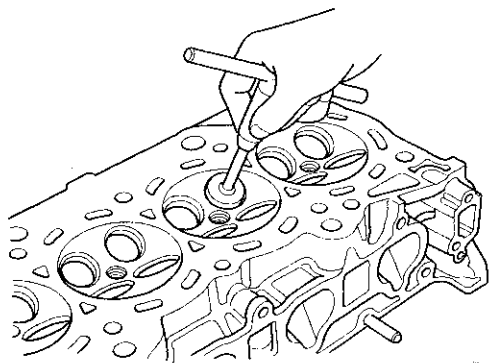

3. Carefully cut a 45° seat, removing only enough material to ensure a smooth and concentric seat.
4. Bevel the upper and lower edges at the angles shown in the illustration. Check the width of the seat and adjust accordingly.

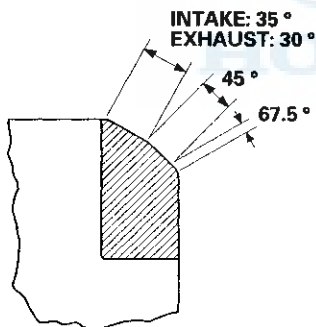

5. Make one more very light pass with the 45° cutter to remove any possible burrs caused by the other cutters.

Valve Seat Width

Standard (New): 1.25–1.55 mm (0.049–0.061 in)

Service Limit: 2.00 mm (0.079 in)

6. After resurfacing the seat, inspect for even valve seating. Apply Prussian Blue compound (A) to the valve face. Insert the valve in its original location in the head, then lift it and snap it closed against the seat several times.

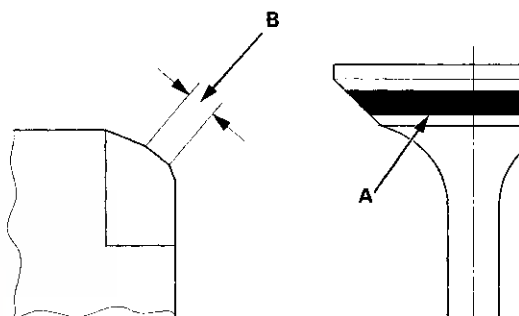

7. The actual valve seating surface (B), as shown by the blue compound, should be centered on the seat.

- If it is too high (closer to the valve stem), you must make a second cut with the 67.5° cutter to move it down, then one more cut with the 45° cutter to restore seat width.
- If it is too low (close to the valve edge), you must make a second cut with the 35° cutter (intake side) or the 30° cutter (exhaust side) to move it up, then make one more cut with the 45° cutter to restore seat width.

NOTE: The final cut should always be made with the 45° cutter.

(cont'd)

Cylinder Head

Valve Seat Reconditioning (cont'd)

8. Insert the intake and exhaust valves in the head, and measure the valve stem installed height (A).

Intake Valve Stem Installed Height

Standard (New): 44.0–44.5 mm (1.73–1.75 in)

Service Limit: 44.7 mm (1.76 in)

Exhaust Valve Stem Installed Height

Standard (New): 44.0–44.5 mm (1.73–1.75 in)

Service Limit: 44.7 mm (1.76 in)

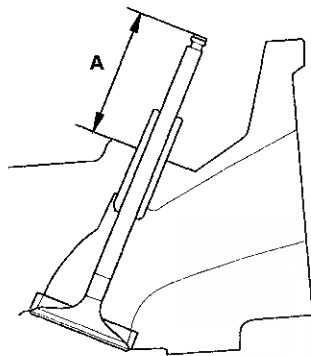

9. If valve stem installed height is beyond the service limit, replace the valve and recheck. If it is still beyond the service limit, replace the cylinder head; the valve seat in the head is too deep.

Valve, Spring, and Valve Seal Installation

Special Tools Required

- Stem Seal Driver, 30 mm 07PAD-0010000
- Valve Spring Compressor Attachment 07757-PJ1010A

1. Coat the valve stems with new engine oil. Install the valves in the valve guides.
2. Check that the valves move up and down smoothly.
3. Install the spring seats on the cylinder head.
4. Install the new valve seals (A) using the 5.5 mm side of the stem seal driver, 30 mm (B).

NOTE: The exhaust valve seal (C) has a black spring (D), and the intake valve seal (E) has a white spring (F). They are not interchangeable.

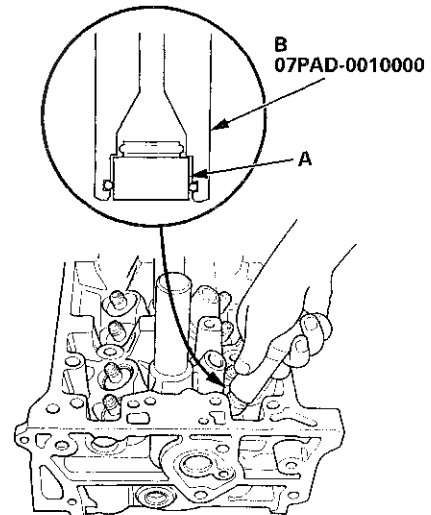
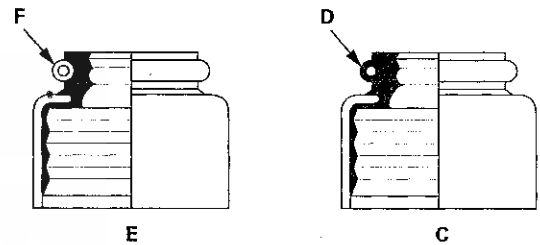



Rocker Arm Assembly Installation

5. Install the valve spring and the spring retainer. Place the end of the valve spring with the closely wound coils toward the cylinder head.
6. Install the valve spring compressor attachment and the valve spring compressor. Compress the spring, and install the valve cotters.

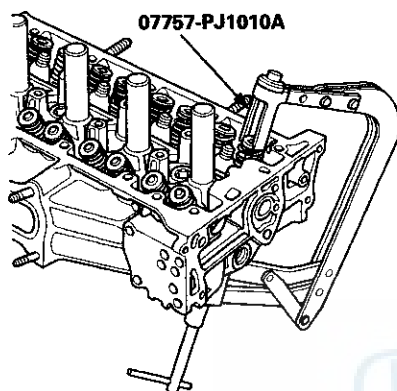

7. Remove the valve spring compressor and the valve spring compressor attachment.
8. Lightly tap the end of each valve stem two or three times with a plastic mallet (A) to ensure proper seating of the valve and the valve cotters. Tap the valve stem only along its axis so you do not bend the stem.

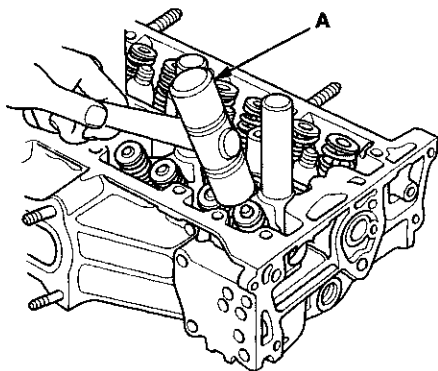

1. Reassemble the rocker arm assembly (see page 6-33).
2. Clean and dry the No. 5 rocker shaft holder mating surface.
3. Apply liquid gasket, P/N 08717-0004, 08718-0003, or 08718-0009 to the cylinder head mating surface of the No. 5 rocker shaft holder, and to the inside edge of the threaded bolt holes. Install the component within 5 minutes of applying the liquid gasket.

NOTE:

- Apply a 3 mm (0.12 in) diameter bead of liquid gasket along the broken line (A).
- If too much time has passed after applying the liquid gasket, remove the old liquid gasket and residue, then reapply new liquid gasket.

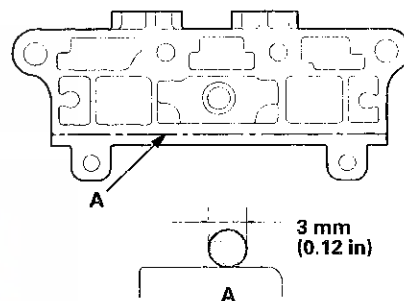

4. Install the lost motion assembly in the cylinder head.
5. Insert the bolts (A) into the rocker shaft holder, then install the rocker arm assembly (B) on the cylinder head.

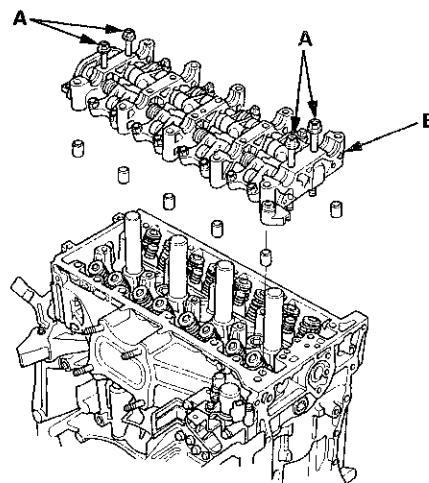

6. Remove the bolts from the rocker shaft holder.

(cont'd)

Cylinder Head

Rocker Arm Assembly Installation (cont'd)

7. Make sure the punch marks on the variable valve timing control (VTC) actuator and the exhaust camshaft sprocket are facing up, then set the camshafts (A) in the holder. Apply new engine oil to the camshaft journals and lobes.

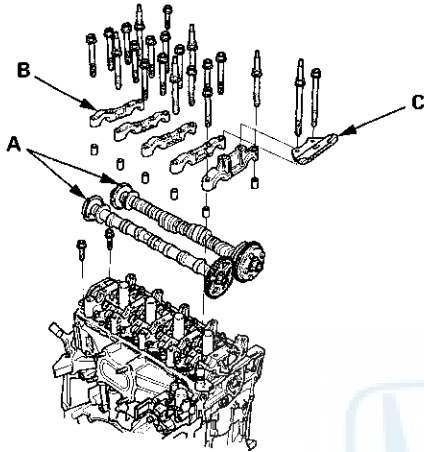

8. Set the camshaft holders (B) and cam chain guide B (C) in place.

9. Tighten the bolts to the specified torque.

NOTE: If the engine does not have bolt (21), skip it and continue the torque sequence.

Specified Torque

8 x 1.25 mm 22 N·m (2.2 kgf·m, 16 lbf·ft)

6 x 1.0 mm 12 N·m (1.2 kgf·m, 8.7 lbf·ft)

6 x 1.0 mm Bolts: (21), (22), (23)

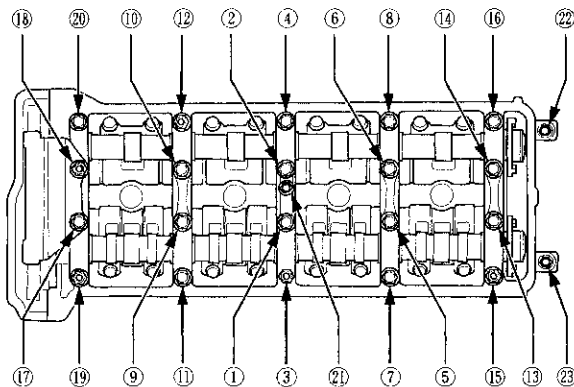

10. Install the cam chain (see page 6-15), then adjust the valve clearance (see page 6-9).

Cylinder Head Installation

1. Install a new coolant separator (A) in the engine block whenever the engine block is replaced.

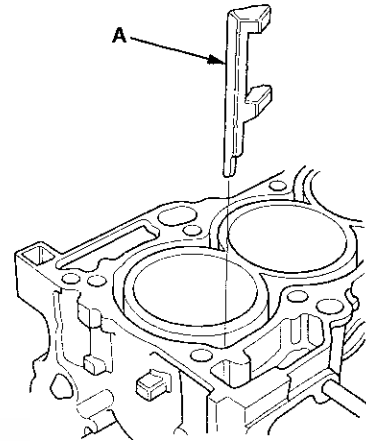

2. Clean the cylinder head and the engine block surface.

3. Install the new cylinder head gasket (A) and the dowel pins (B) on the engine block. Always use a new cylinder head gasket.

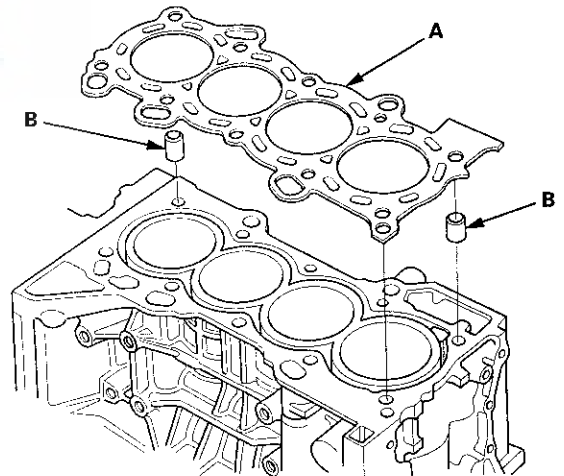



4. Set the crankshaft to top dead center (TDC). Align the TDC mark (A) on the crankshaft sprocket with the pointer (B) on the engine block.

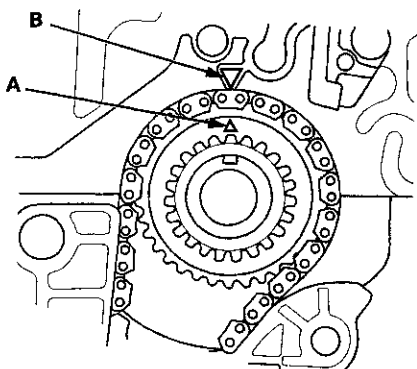

5. Install the cylinder head on the engine block.

6. Measure the diameter of each cylinder head bolt at point A and point B.

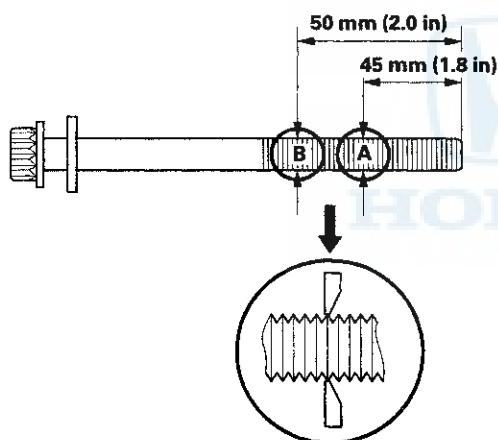

7. If either diameter is less than 10.6 mm (0.42 in), replace the cylinder head bolt.

8. Apply new engine oil to the threads and under the bolt heads of all cylinder head bolts.

9. Torque the cylinder head bolts in sequence to 39 N·m (4.0 kgf·m, 29 lbf·ft). Use a beam-type torque wrench. When using a preset click-type torque wrench, be sure to tighten slowly and do not overtighten. If a bolt makes any noise while you are torquing it, loosen the bolt and retighten it from the first step.

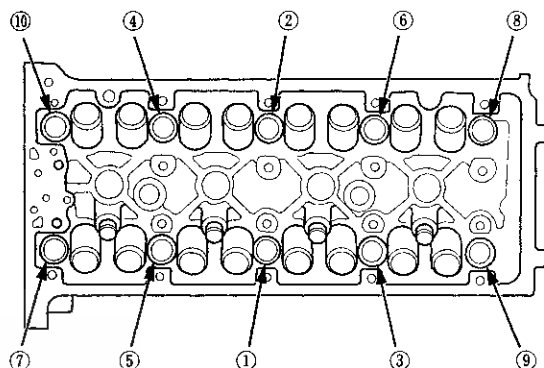

10. After torquing, tighten all cylinder head bolts in two steps (90° per step) using the sequence shown in step 9. If you are using a new cylinder head bolt, tighten the bolt an extra 90°.

NOTE: Remove the cylinder head bolt if you tightened it beyond the specified angle, and go back to step 6 of the procedure. Do not loosen it back to the specified angle.

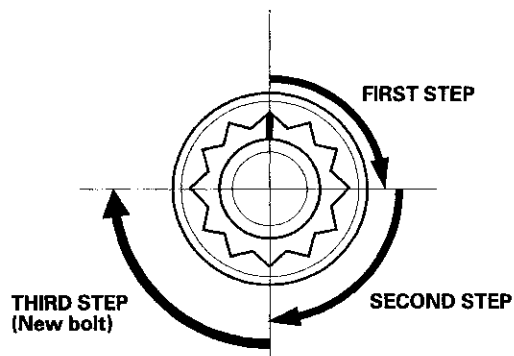

(cont'd)

Cylinder Head

Cylinder Head Installation (cont'd)

11. Install the rocker arm assembly (see page 6-43).
12. Install the cam chain (see page 6-15).
13. Connect the following engine wire harness connectors, and install the wire harness clamps to the cylinder head:
 - Engine coolant temperature (ECT) sensor 1 connector
 - Camshaft position (CMP) sensor A (Intake) connector
 - Camshaft position (CMP) sensor B (Exhaust) connector
 - Rocker arm oil control solenoid connector
 - Rocker arm oil pressure switch connector
 - Evaporative emission (EVAP) canister purge valve connector
 - Variable valve timing control (VTC) oil control solenoid valve connector
 - Engine oil pressure switch connector
14. Install the two bolts (A) securing the connecting pipe.

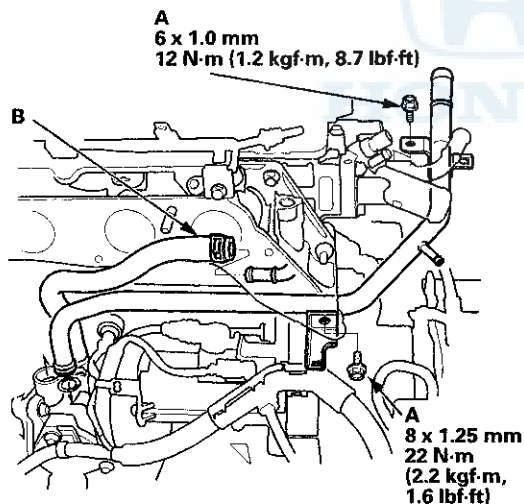

15. Connect the water bypass hose (B).

16. Connect the upper radiator hose (A), the heater hoses (B), and the water bypass hose (C).

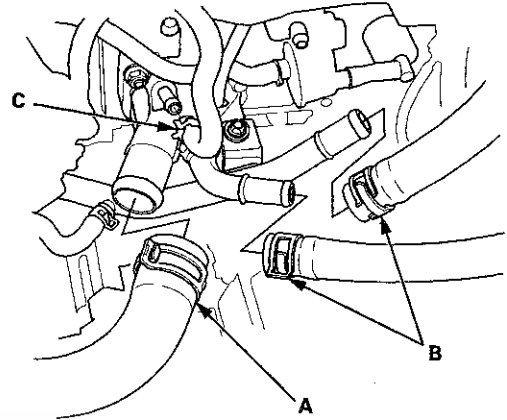

17. Install the four bolts securing the EVAP canister purge valve bracket.

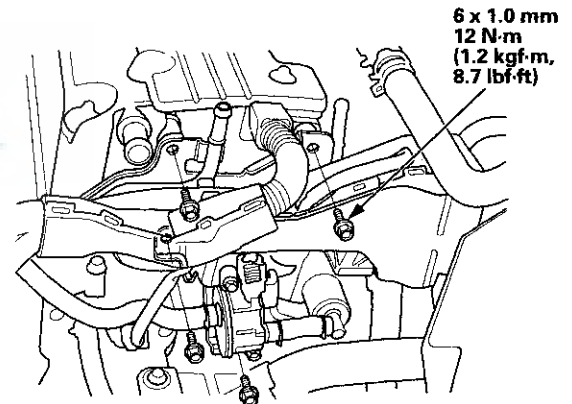



18. Connect the four fuel injector connectors (A), the engine mount control solenoid valve connector (B), and install the ground cables (C).

6 x 1.0 mm
12 N·m
(1.2 kgf·m, 8.7 lbf·ft)

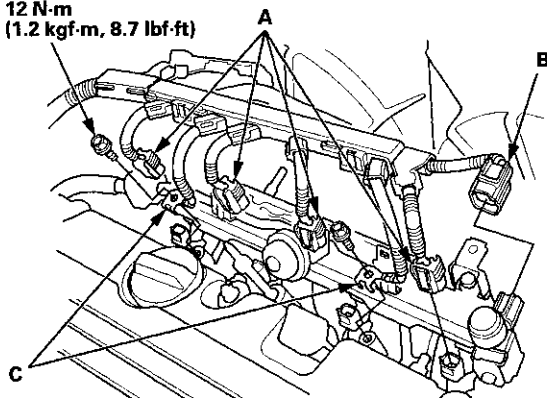

19. Connect the fuel feed hose (A) (see page 11-316), then install the quick-connect fitting cover (B).

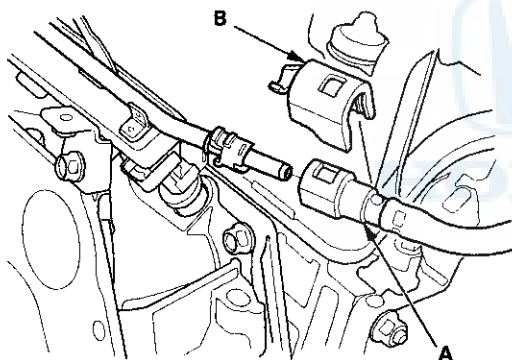

20. Connect the EVAP canister hose (A).

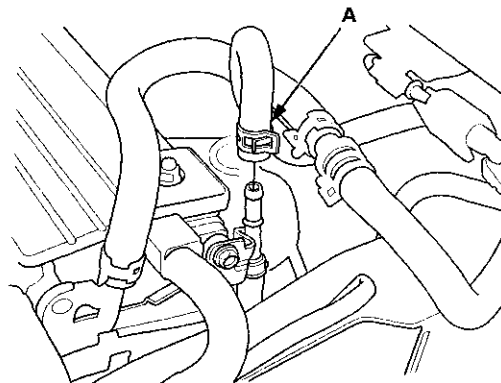

21. Install the catalytic converter (see page 11-339).
22. Install the intake manifold (see page 9-6).
23. Install the drive belt (see page 4-30).
24. Install the strut brace (if equipped) (see page 20-306).
25. After installation, check that all tubes, hoses, and connectors are installed correctly.
26. Inspect for fuel leaks. Turn the ignition switch to ON (II) (do not operate the starter) so the fuel pump runs for about 2 seconds and pressurizes the fuel line. Repeat this operation three times, then check for fuel leakage at any point in the fuel line.
27. Refill the radiator with engine coolant, and bleed the air from the cooling system (see step 5 on page 10-6).
28. Check for fluid leaks.
29. Do the engine control module (ECM)/powertrain control module (PCM) idle lean procedure (see page 11-293).
30. Do the crankshaft position (CKP) pattern clear/CKP pattern lean procedure (see page 11-5).
31. Inspect the idle speed (see page 11-292).
32. Inspect the ignition timing (see page 4-19).

Cylinder Head

Sealing Bolt Installation

NOTE: When installing the sealing bolt, always use a new washer.

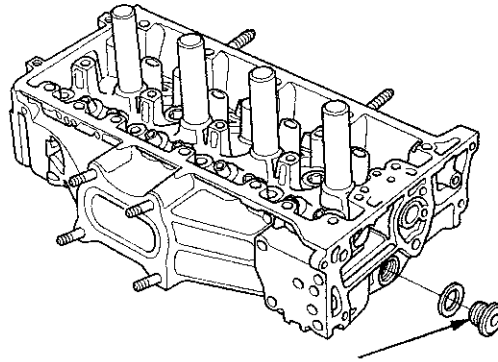

22 x 1.5 mm
74 N·m (7.5 kgf·m, 54 lbf·ft)

